



Detcon Model Series
DM-500IS OLED
Explosion Proof and Intrinsically Safe Toxic Gas Sensors



Operator's Installation and Instruction Manual

◆ DETCON, Inc.
4055 Technology Forest Blvd. Suite 100,
The Woodlands, Texas 77381
Ph.281.367.4100 / Fax 281.298.2868
www.detcon.com

This page left intentionally blank

Table of Contents

1.0	Description.....	2
1.1	Sensor Technology	2
1.2	Universal Microprocessor Control Transmitter Circuit.....	3
1.3	Base Connector Board.....	3
1.4	Explosion Proof Enclosure	3
2.0	Principle Of Operation.....	4
3.0	Application	5
3.1	Sensor Placement/Mounting.....	5
3.2	Interference Data	5
3.3	Interference Gas List	6
3.4	Interference Gas Table (page 1 of 5).....	7
4.0	Specifications.....	12
5.0	Installation.....	13
5.1	Field Wiring Table (4-20 mA output)	13
5.2	Sensor Location.....	13
5.3	Local Electrical Codes.....	15
5.4	Installation Procedure.....	15
5.5	Remote Mounting Applications	16
6.0	Startup	17
6.1	Initial Operational Tests	17
7.0	Operating Software & Magnetic Interface.....	18
7.1	Normal Operation.....	18
7.2	Calibration Mode.....	18
7.2.1	<i>Zero Adjustment</i>	18
7.2.2	<i>Span Adjustment</i>	18
7.3	Program Mode.....	18
7.3.1	<i>Program Status</i>	18
7.3.2	<i>Calibration Level Adjustment</i>	18
7.4	Programming Magnet Operating Instructions	19
8.0	Software Flow Chart	20
9.0	Calibration.....	20
9.1	Calibration Procedure – Zero	20
9.2	Calibration Procedure – Span.....	21
9.3	Additional Notes.....	22
9.4	Calibration Frequency	22
10.0	Status of Programming, Calibration Level and Sensor Life.....	22
11.0	Program Features	23
12.0	Universal Transmitter Feature (Re-Initialization)	24
13.0	Trouble Shooting	25
14.0	Spare Parts List.....	27
15.0	Warranty	29
16.0	Service Policy	29

17.0 Revision History.....	30
-----------------------------------	-----------

Table of Figures

Figure 1 DM-500IS Sensor	2
Figure 2 Construction of Electrochemical Sensor.....	2
Figure 3 Universal Microprocessor Control Transmitter circuit	3
Figure 4 Base connector board	3
Figure 5 Explosion-Proof Enclosure	4
Figure 6 Functional Block Diagram.....	4
Figure 7 Typical Installation	14
Figure 8 Typical Outline and Mounting Dimensions.....	15
Figure 9 Sensor wiring	16
Figure 10 Remote wiring diagram.....	16
Figure 11 Programming magnet.....	19
Figure 12 Programming Switch locations	19
Figure 13 Software Flow Chart	20
Figure 14 Spare parts diagram.....	27

List of Tables

Table 1 Model #, Gas Name and Symbol.....	1
Table 2 Sensor cell specifications	12
Table 3 Field wiring Table	13
Table 4 Over-current Protection per AWG	13
Table 5 IS Sensor Head / Plug-in Replacement Sensor Cell.....	28

This manual covers the following Models...
Table 1 Model #, Gas Name and Symbol

Model #	Gas Name	Symbol
DM-500-C2H3O	Acetaldehyde	C2H3O
DM-500-C2H2	Acetylene	C2H2
DM-500-C3H3N	Acrylonitrile	C3H3N
DM-500-NH3 (-20°C)	Ammonia	NH3
DM-501-NH3 (-40°C)	Ammonia	NH3
DM-502-NH3	Ammonia (continuous exposure)	NH3
DM-500-AsH3	Arsine	AsH3
DM-500-Br2	Bromine	Br2
DM-500-C4H6	Butadiene	C4H6
DM-500-CS2	Carbon Disulfide	CS2
DM-500-CO	Carbon Monoxide	CO
DM-500-COS	Carbonyl Sulfide	COS
DM-500-CL2	Chlorine	CL2
DM-500-CLO2	Chlorine Dioxide (>50 ppm range)	CLO2
DM-501-CLO2	Chlorine Dioxide (≤50 ppm range)	CLO2
DM-500-B2H6	Diborane	B2H6
DM-500-C2H6S	Dimethyl Sulfide	C2H6S
DM-500-C3H5OCL	Epichlorohydrin	C3H5OCL
DM-500-C2H5OH	Ethanol	C2H5OH
DM-500-C2H5SH	Ethyl Mercaptan	C2H5SH
DM-500-C2H4	Ethylene	C2H4
DM-500-C2H4O	Ethylene Oxide	C2H4O
DM-500-F2	Fluorine	F2
DM-500-CH2O	Formaldehyde	CH2O
DM-500-GeH4	Germane	GeH4
DM-500-N2H4	Hydrazine	N2H4
DM-500-H2	Hydrogen (ppm range)	H2
DM-501-H2	Hydrogen (% LEL range)	H2
DM-500-HBr	Hydrogen Bromide	HBr
DM-500-HCL	Hydrogen Chloride	HCL
DM-500-HCN	Hydrogen Cyanide	HCN
DM-500-HF	Hydrogen Fluoride	HF
DM-500-H2S	Hydrogen Sulfide	H2S
DM-500-CH3OH	Methanol	CH3OH
DM-500-CH3SH	Methyl Mercaptan	CH3SH
DM-500-NO	Nitric Oxide	NO
DM-500-NO2	Nitrogen Dioxide	NO2
DM-500-O3	Ozone	O3
DM-500-COCL2	Phosgene	COCL2
DM-500-PH3	Phosphine	PH3
DM-500-SiH4	Silane	SiH4
DM-500-SO2	Sulfur Dioxide	SO2
DM-500-C4H8S	Tetrahydrothiophene	C4H8S
DM-500-C4H4S	Thiophane	C4H4S
DM-500-C6H5CH3	Toluene	C6H5CH3
DM-500-C4H6O2	Vinyl Acetate	C4H6O2
DM-500-C2H3CL	Vinyl Chloride	C2H3CL

1.0 Description

Detcon MicroSafe™ Model DM-500IS, toxic sensors are non-intrusive “Smart” sensors designed to detect and monitor for toxic gas in the ppm range. One of the primary features of the sensor is its method of automatic calibration which guides the user through each step via instructions displayed on the OLED Display. The sensor features LED indicators for FAULT and CAL status and is equipped with a standard analog 4-20 mA output. The microprocessor supervised electronics are packaged as a universal plug-in transmitter module that mates to a standard connector board. Both are housed in an explosion proof conduit that includes a glass lens. A 16 character alpha/numeric indicator is used to display sensor readings as well as the sensor’s menu driven features via a hand-held programming magnet.



Figure 1 DM-500IS Sensor

Typical ranges of detection are 0-10ppm, 0-25ppm, 0-50ppm and 0-100ppm. Other ranges are available and all ranges are covered by this manual. To determine sensor model number, reference the label located on the enclosure cover. To determine gas type and range, reference labeling on the intrinsically safe sensor head.

1.1 Sensor Technology

The sensors are electrolytic chemical cells. Each cell consists of three electrodes embedded in an electrolyte solution all housed beneath a diffusion membrane. Sensitivity to specific target gases is achieved by varying composition of any combination of the sensor components. Good specificity is achieved in each sensor type. The cells are diffusion limited via small capillary barriers resulting in long service life of up to 3 or more years. The fuel cell is packaged as a field replaceable plug-in sensor via gold plated pins. Pre-amplifier and intrinsically safe barrier circuits are epoxy potted in the stainless steel housing and include the mating sockets for the sensor.

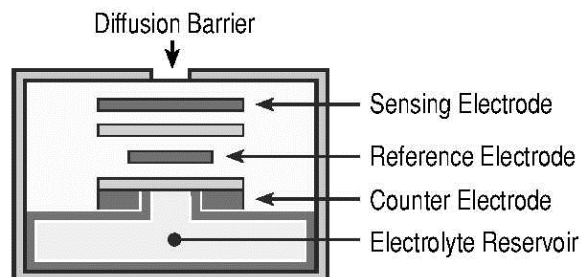

Figure 2 Construction of Electrochemical Sensor

1.2 Universal Microprocessor Control Transmitter Circuit

The control circuit is microprocessor based and is packaged as a universal plug-in field replaceable module, facilitating easy replacement and minimum down time. The universality includes the ability to set it for any range concentration and for any gas type. These gas and range settings must be consistent with the IS Sensor Head it is mated with. Circuit functions include a basic sensor pre-amplifier, on-board power supplies, microprocessor, back lit alpha numeric display, fault and calibration status LED indicators, magnetic programming switches, and a linear 4-20 mA DC output.

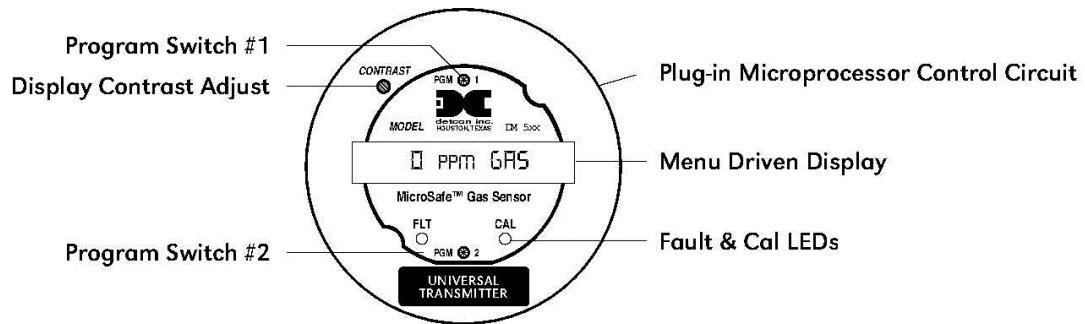

Figure 3 Universal Microprocessor Control Transmitter circuit

1.3 Base Connector Board

The base connector board is mounted in the explosion proof enclosure and includes: the mating connector for the control circuit, reverse input and secondary transient suppression, input filter and lugless terminals for all field wiring.

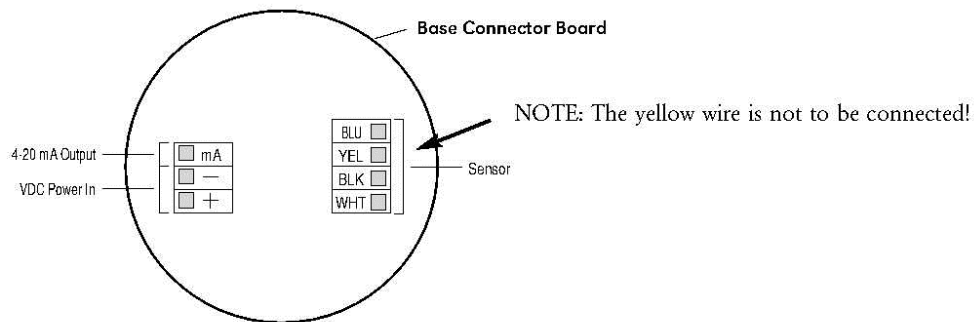

Figure 4 Base connector board

1.4 Explosion Proof Enclosure

The transmitter electronics are packaged in a cast metal explosion proof enclosure. The enclosure is fitted with a threaded cover that has a glass lens window. Magnetic program switches located behind the transmitter module face plate are activated through the lens window via a hand-held magnetic programming tool allowing non-intrusive operator interface with the sensor. Calibration can be accomplished without removing the cover or declassifying the area. Electrical classification is Class I; Groups B, C, D; Division 1 (explosion proof).

The sensor housing section employs an Intrinsically Safe Barrier circuit which allows for the safe usage of plastic housing materials in the lower section. This design benefit avoids the requirement for stainless steel flame arrestors which reduce the sensitivity and response time to “active” gas species such as NH₃, CL₂, CLO₂, and HCL...etc.

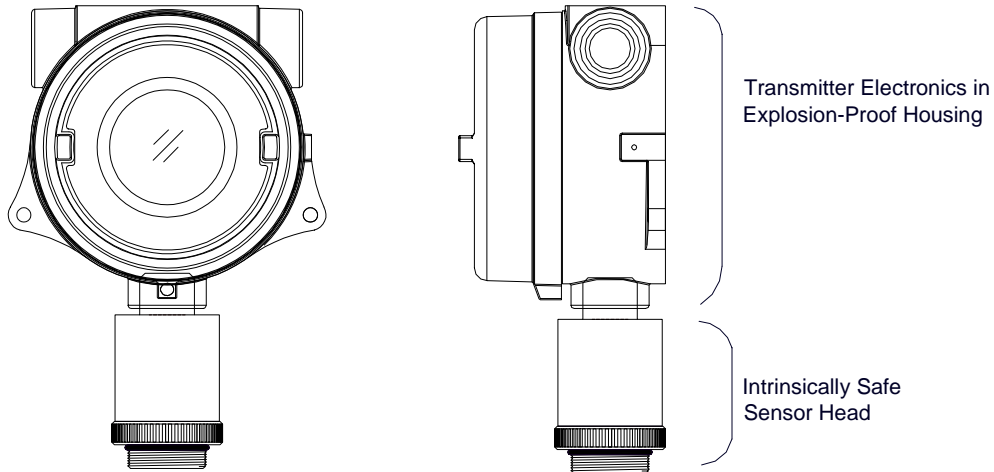

Figure 5 Explosion-Proof Enclosure

2.0 Principle Of Operation

Method of detection is by an electrochemical reaction at the surface of an electrode called the sensing electrode. Air and gas diffuse through the capillary diffusion barrier. The controlling circuit maintains a small external operating voltage between the sensing and counter electrodes of the proper bias and magnitude so that no current flows to or from the reference electrode while its potential is maintained at the correct fixed voltage - usually ground. The electrochemical reaction creates a change in current flow from the counter electrode to the sensing electrode. This change in current is proportional to the gas concentration and is reversible. The quick response of the sensor results in continuous monitoring of ambient air conditions. The Intrinsically Safe Sensor Housing design allows direct contact of the target gas to the electrochemical sensor, thus maximizing response time, detectability and repeatability.

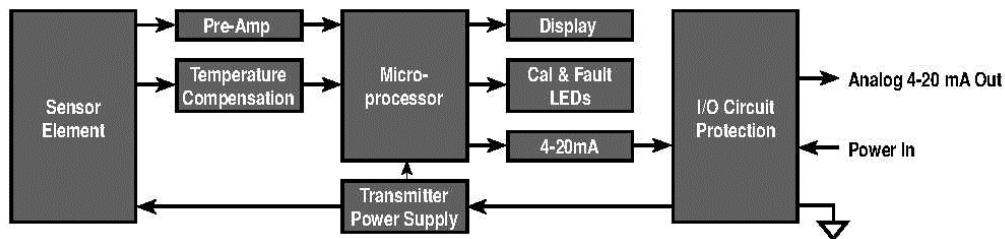

Figure 6 Functional Block Diagram

3.0 Application

3.1 Sensor Placement/Mounting

Sensor location should be reviewed by facility engineering and safety personnel. Area leak sources and perimeter mounting are typically used to determine number and location of sensors. The sensors are generally located 2 - 4 feet above grade.

3.2 Interference Data

Detcon Model DM-500IS series electrochemical sensors are subject to interference from other gases. This interaction is shown in the table in section 3.4 as the relation between the amount of the interfering gas applied to the sensor, and the corresponding reading that will occur. All measurements are in ppm unless otherwise noted.

The table is laid out with the Model Number of each sensor in a column on the left side of the page. The interfering gases are listed in a row across the top of the page. Each page lists all Model Numbers but 5 pages are necessary to list all interfering gases, thus each page is a repeat of the full line of Detcon sensors. Be sure to reference each page to ascertain the full listing of interfering gases for a particular sensor.

As an example, the first listing shows that the Model DM-500IS-C2H30 acetaldehyde sensor will have an interference reading of 340 ppm if 40 ppm of C₂H₂ (Acetylene) is applied.

NOTE: Interference factors may differ from sensor to sensor and with life time. It is not advisable to calibrate with interference gases. They should be used as a guide only

3.3 Interference Gas List

Gas Name	Symbol	Gas Name	Symbol
Acetaldehyde	C2H3O	Hydrocarbons	C-H's
Acetylene	C2H2	Hydrocarbons (unsaturated)	C-H's (u)
Acrylonitrile	C3H3N	Hydrogen	H2
Alcohols	Alcohols	Hydrogen Bromide	HBr
Amines	Amines	Hydrogen Chloride	HCL
Ammonia	NH3	Hydrogen Cyanide	HCN
Arsenic Trifluoride	AsF3	Hydrogen Fluoride	HF
Arsenic Pentafluoride	AsF5	Hydrogen Selenide	HSe
Arsine	AsH3	Hydrogen Sulfide	H2S
Boron Trifluoride	BF3	Iodine	I2
Bromine	Br2	Isopropanol	C3H8O
Butadiene	C4H6	Methane	CH4
Buten-1	Buten-1	Methanol	CH3OH
Carbon Dioxide	CO2	Methyl-Ethyl-Ketone	C4H8O
Carbon Disulfide	CS2	Methyl Mercaptan	CH3SH
Carbon Oxide Sulfide	COS	Nitric Oxide	NO
Carbon Monoxide	CO	Nitrogen	N2
Carbonyl Sulfide	COS	Nitrogen Dioxide	NO2
Chlorine	CL2	Ozone	O3
Chlorine Dioxide	CLO2	Phosgene	COCL2
Chlorine Trifluoride	CLF3	Phosphine	PH3
Diborane	B2H6	Phosphorous Trifluoride	PF3
Dimethyl Sulfide	C2H6S	Silane	SiH4
Disilane	Si2H6	Silicon	Si
Epichlorohydrin	C3H5OCL	Silicon Tetra Fluoride	SiF4
Ethanol	C2H5OH	Sulfur Dioxide	SO2
Ethyl Mercaptan	C2H5SH	Tetrahydrothiophene	C4H8S
Ethylene	C2H4	Thiophane	C4H4S
Ethylene Oxide	C2H4O	Toluene	C6H5CH3
Fluorine	F2	Tungsten Hexafluoride	WF6
Formaldehyde	CH2O	Vinyl Acetate	C4H6O2
Germane	GeH4	Vinyl Chloride	C2H3CL
Hydrazine	N2H4		

3.4 Interference Gas Table (page 1 of 5)

NOTE: Reference the listing in Table 1 to match model number with gas name. Reference the listing in section 3.3 to match the interfering gas symbol with the gas name.

Model Number	C2H3O	C2H2	C3H3N	Alcohols	Amines	NH3	AsF3	AsF5	AsH3	BF3	Br2	C4H6	Buten-1
DM-500IS-C2H3O	n/a	40=340	40=75	n/d	n/d	n/d	n/d	n/d	n/d	n/d	n/d	40=170	n/d
DM-500IS-C2H2	340=40	n/a	340=75	n/d	n/d	n/d	n/d	n/d	n/d	n/d	n/d	340=170	n/d
DM-500IS-C3H3N	75=40	75=340	n/d	n/d	n/d	n/d	n/d	n/d	n/d	n/d	n/d	75=170	n/d
DM-500IS-NH3 (-20°C)	n/d	n/d	n/d	1000=0	yes n/d	n/a	n/d	n/d	1=0	n/d	n/d	n/d	n/d
DM-501IS-NH3 (-40°C)	n/d	n/d	n/d	n/d	yes n/d	n/d	n/d	n/d	1=0	n/d	n/d	n/d	n/d
DM-502IS-NH3 (CE)	n/d	n/d	n/d	n/d	n/d	n/d	n/d	n/d	n/a	n/d	n/d	n/d	n/d
DM-500IS-AsH3	n/d	n/d	n/d	n/d	n/d	100=0.01	n/d	n/a	n/d	n/d	n/d	n/d	n/d
DM-500IS-Br2	n/d	n/d	n/d	n/d	n/d	n/d	n/d	n/d	n/d	n/d	n/a	n/d	n/d
DM-500IS-C4H6	170=40	170=340	170=75	n/d	n/d	n/d	n/d	n/d	n/d	n/d	n/d	n/a	n/d
DM-500IS-CS2	140=40	140=340	140=75	n/d	n/d	n/d	n/d	n/d	n/d	n/d	n/d	140=170	n/d
DM-500IS-CO	n/d	n/d	n/d	n/d	n/d	n/d	n/d	n/d	n/d	n/d	n/d	n/d	n/d
DM-500IS-COS	135=40	135=340	135=75	n/d	n/d	n/d	n/d	n/d	n/d	n/d	n/d	135=170	n/d
DM-500IS-CL2	n/d	n/d	n/d	n/d	n/d	n/d	n/d	n/d	n/d	n/d	1=0.55	n/d	n/d
DM-500IS-CLO2 (>10ppm)	n/d	n/d	n/d	n/d	n/d	n/d	n/d	n/d	n/d	n/d	1=0.18	n/d	n/d
DM-501IS-CLO2 (≤10ppm)	n/d	n/d	n/d	n/d	n/d	n/d	n/d	n/d	n/d	n/d	n/d	n/d	n/d
DM-500IS-B2H6	n/d	n/d	n/d	n/d	n/d	100=0.013	n/d	n/d	0.15=0.2	n/d	n/d	n/d	n/d
DM-500IS-C2H6S	150=40	150=340	150=75	n/d	n/d	n/d	n/d	n/d	n/d	n/d	n/d	150=170	n/d
DM-500IS-C3H5OCL	50=40	50=340	50=75	n/d	n/d	n/d	n/d	n/d	n/d	n/d	n/d	50=170	n/d
DM-500IS-C2H5OH	180=40	180=340	180=75	n/d	n/d	n/d	n/d	n/d	n/d	n/d	n/d	180=170	n/d
DM-500IS-C2H5SH	n/d	n/d	n/d	n/d	n/d	n/d	n/d	n/d	n/d	n/d	n/d	n/d	n/d
DM-500IS-C2H4	220=40	220=340	220=75	n/d	n/d	n/d	n/d	n/d	n/d	n/d	n/d	220=170	n/d
DM-500IS-C2H4O	275=40	275=40	275=75	n/d	n/d	n/d	n/d	n/d	n/d	n/d	n/d	275=170	n/d
DM-500IS-F2	n/d	n/d	n/d	1000=0	n/d	n/d	n/d	n/d	0.1=0	n/d	yes n/d	n/d	n/d
DM-500IS-CH2O	330=40	330=340	330=75	n/d	n/d	n/d	n/d	n/d	n/d	n/d	n/d	330=170	n/d
DM-500IS-GeH4	n/d	n/d	n/d	n/d	n/d	100=<1	n/d	n/d	0.2=0.14	n/d	n/d	n/d	n/d
DM-500IS-N2H4	n/d	n/d	n/d	1000=0	n/d	200=0.04	n/d	n/d	0.1=0.1	n/d	n/d	n/d	n/d
DM-500IS-H2 (ppm)	n/d	n/d	n/d	n/d	n/d	n/d	n/d	n/d	n/d	n/d	n/d	n/d	n/d
DM-501IS-H2 (LEL)	n/d	n/d	n/d	n/d	n/d	100=0	n/d	n/d	n/d	n/d	n/d	n/d	n/d
DM-500IS-HBr	n/d	n/d	n/d	1000=0	No	n/d	n/d	n/d	0.1=0.3	n/d	n/d	n/d	n/d
DM-500IS-HCL	n/d	n/d	n/d	1000=0	No	n/d	n/d	n/d	0.1=0.3	n/d	n/d	n/d	n/d
DM-500IS-HCN	n/d	n/d	n/d	1000=0	n/d	n/d	n/d	n/d	0.1=0	n/d	yes n/d	n/d	n/d
DM-500IS-HF	n/d	n/d	n/d	1000=0	n/d	n/d	yes n/d	yes n/d	0.1=0	yes n/d	n/d	n/d	n/d
DM-500IS-H2S	n/d	n/d	n/d	n/d	n/d	n/d	n/d	n/d	n/d	n/d	n/d	n/d	n/d
DM-500IS-CH3OH	415=40	415=340	415=75	n/d	n/d	n/d	n/d	n/d	n/d	n/d	n/d	415=170	n/d
DM-500IS-CH3SH	n/d	n/d	n/d	n/d	n/d	n/d	n/d	n/d	n/d	n/d	n/d	275=170	n/d
DM-500IS-NO	n/d	n/d	n/d	n/d	n/d	n/d	n/d	n/d	n/d	n/d	n/d	n/d	n/d
DM-500IS-NO2	n/d	n/d	n/d	n/d	n/d	n/d	n/d	n/d	n/d	n/d	n/d	n/d	n/d
DM-500IS-O3	n/d	n/d	n/d	n/d	n/d	n/d	n/d	n/d	0.1=0.05	n/d	yes n/d	n/d	n/d
DM-500IS-COCL2	n/d	n/d	n/d	1000=0	n/d	50=0.5	n/d	n/d	n/d	n/d	n/d	n/d	n/d
DM-500IS-PH3	n/d	n/d	n/d	n/d	n/d	100=0.01	n/d	n/d	1=1	n/d	n/d	n/d	n/d
DM-500IS-SiH4	n/d	n/d	n/d	n/d	n/d	100=<1	n/d	n/d	0.2=0.14	n/d	n/d	n/d	n/d
DM-500IS-SO2	n/d	n/d	n/d	n/d	n/d	n/d	n/d	n/d	n/d	n/d	n/d	n/d	n/d
DM-500IS-C4H8S	n/d	n/d	n/d	n/d	n/d	n/d	n/d	n/d	n/d	n/d	n/d	n/d	n/d
DM-500IS-C4H4S	45=40	45=340	45=75	n/d	n/d	n/d	n/d	n/d	n/d	n/d	n/d	45=170	1%=1.8
DM-500IS-C6H5CH3	55=40	55=340	55=75	n/d	n/d	n/d	n/d	n/d	n/d	n/d	n/d	55=170	n/d
DM-500IS-C4H6O2	200=40	200=340	200=75	n/d	n/d	n/d	n/d	n/d	n/d	n/d	n/d	200=170	n/d
DM-500IS-C2H3CL	200=40	200=340	200=75	n/d	n/d	n/d	n/d	n/d	n/d	n/d	n/d	200=170	n/d

n/a = not applicable

n/d = no data

Interference Gas Table (page 2 of 5)

Model Number	CO2	CS2	CO	COS	CL2	CLO2	CLF3	B2H6	C2H6S	Si2H6	C3H5OCL	C2H5OH
DM-500IS-C2H3O	n/d	40=140	40=100	40=135	n/d	n/d	n/d	n/d	40=150	n/d	40=50	40=180
DM-500IS-C2H2	n/d	340=140	340=100	340=135	n/d	n/d	n/d	n/d	340=150	n/d	340=50	340=180
DM-500IS-C3H3N	n/d	75=140	75=100	75=135	n/d	n/d	n/d	n/d	75=150	n/d	75=50	75=180
DM-500IS-NH3 (-20°C)	5000=0	n/d	1000=0	n/d	1=0	n/d	n/d	0.1=0	n/d	n/d	n/d	n/d
DM-501IS-NH3 (-40°C)	5000=0	n/d	300=100	n/d	5=0	n/d	n/d	0.1=0	n/d	n/d	n/d	n/d
DM-502IS-NH3 (CE)	n/d	n/d	300=8	n/d	1=1	10%=15	n/d	n/d	n/d	n/d	n/d	n/d
DM-500IS-AsH3	5000=0	n/d	300=0	n/d	0.5 = -0.04	n/d	n/d	0.2=0.15	n/d	5=yes n/d	n/d	n/d
DM-500IS-Br2	n/d	n/d	300=0	n/d	1=2	1=6	n/d	n/d	n/d	n/d	n/a	n/d
DM-500IS-C4H6	n/d	170=140	170=100	170=135	n/d	n/d	n/d	n/d	170=150	n/d	170=50	170=180
DM-500IS-CS2	n/d	n/a	140=100	140=135	n/d	n/d	n/d	n/d	140=150	n/d	140=50	140=180
DM-500IS-CO	n/d	n/d	n/a	n/d	1=0	n/d	n/d	n/d	n/d	n/d	n/d	200=0
DM-500IS-COS	n/d	135=140	135=100	n/a	n/d	n/d	n/d	n/d	135=150	n/d	135=50	135=180
DM-500IS-CL2	n/d	n/d	300=0	n/d	n/a	n/d	n/d	n/d	n/d	n/d	n/d	n/d
DM-500IS-CLO2 (>10ppm)	n/d	n/d	300=0	n/d	3=1	n/a	n/d	n/d	n/d	n/d	n/d	n/d
DM-501IS-CLO2 (≤10ppm)	5000=0	n/d	1000=0	n/d	1=0.9	n/a	yes n/d	0.1=0	n/d	n/d	n/d	n/d
DM-500IS-B2H6	5000=0	n/d	300=0	n/d	0.5 = -0.06	n/d	n/d	n/a	n/d	5=yes n/d	n/d	n/d
DM-500IS-C2H6S	n/d	150=140	150=100	150=135	n/d	n/d	n/d	n/d	n/a	n/d	150=50	150=180
DM-500IS-C3H5OCL	n/d	50=140	50=100	50=135	n/d	n/d	n/d	n/d	50=150	n/d	n/a	50=180
DM-500IS-C2H5OH	n/d	180=140	180=100	180=135	n/d	n/d	n/d	n/d	180=150	n/d	180=50	n/a
DM-500IS-C2H5SH	n/d	n/d	300≤5	n/d	1 = -0.6	n/d	n/d	n/d	n/d	n/d	n/d	n/d
DM-500IS-C2H4	n/d	220=140	220=100	220=135	n/d	n/d	n/d	n/d	220=150	n/d	220=50	220=180
DM-500IS-C2H4O	n/d	275=100	275=100	275=135	n/d	n/d	n/d	n/d	275=150	n/d	275=50	275=180
DM-500IS-F2	5000=0	n/d	1000=0	n/d	1=1.3	n/d	n/d	n/d	n/d	n/d	n/d	n/d
DM-500IS-CH2O	n/d	330=140	330=100	330=135	n/d	n/d	n/d	n/d	330=150	n/d	330=50	330=180
DM-500IS-GeH4	5000=0	n/d	300=0	n/d	0.5 = -0.04	n/d	n/d	0.2=0.11	n/d	5=yes n/d	n/d	n/d
DM-500IS-N2H4	5000=0	n/d	1000=0	n/d	1=0	n/d	n/d	n/d	n/d	n/d	n/d	n/d
DM-500IS-H2 (ppm)	n/d	n/d	300=<30	n/d	1=0	n/d	n/d	n/d	n/d	n/d	n/d	n/d
DM-501IS-H2 (LEL)	1000=0	n/d	50=6	n/d	5=0	n/d	n/d	n/d	n/d	n/d	n/d	n/d
DM-500IS-HBr	5000=0	n/d	1000=0	n/d	5=1	n/d	yes n/d	n/d	n/d	n/d	n/d	n/d
DM-500IS-HCL	5000=0	n/d	1000=0	n/d	5=1	n/d	1=yes n/d	n/d	n/d	n/d	n/d	n/d
DM-500IS-HCN	5000=0	n/d	1000=0	n/d	5 = -1	n/d	n/d	n/d	n/d	n/d	n/d	n/d
DM-500IS-HF	5000=0	n/d	1000=0	n/d	1=0.4	n/d	yes n/d	0.1=0	n/d	n/d	n/d	n/d
DM-500IS-H2S	n/d	n/d	300≤1.5	n/d	1 = ≈ -0.2	n/d	n/d	n/d	n/d	n/d	n/d	n/d
DM-500IS-CH3OH	n/d	415=140	415=100	415=135	n/d	n/d	n/d	n/d	415=150	n/d	415=50	415=180
DM-500IS-CH3SH	n/d	n/d	300 ≤ 3	n/d	1 = -0.4	n/d	n/d	n/d	n/d	n/d	n/d	n/d
DM-500IS-NO	n/d	n/d	300=0	n/d	1=0	n/d	n/d	n/d	n/d	n/d	n/d	n/d
DM-500IS-NO2	n/d	n/d	300=0	n/d	1= ≈1	n/d	n/d	n/d	n/d	n/d	n/d	n/d
DM-500IS-O3	5000=0	n/d	300=0	n/d	1=1.4	0.1=0.12	1=1(theor.)	n/d	n/d	n/d	n/d	n/d
DM-500IS-COCL2	5000=0	n/d	1000=0	n/d	1=0	n/d	n/d	n/d	n/d	n/d	n/d	n/d
DM-500IS-PH3	5000=0	n/d	300=0	n/d	0.5 = -0.04	n/d	n/d	0.2=0.15	n/d	5=yes n/d	n/d	n/d
DM-500IS-SiH4	5000=0	n/d	300=0	n/d	0.5 = -0.04	n/d	n/d	0.2=0.11	n/d	5=yes n/d	n/d	n/d
DM-500IS-SO2	n/d	n/d	300=<5	n/d	1=<0.5	n/d	n/d	n/d	n/d	n/d	n/d	n/d
DM-500IS-C4H8S	5000=0	n/d	0.1%=1.2	1%=10	n/d	n/d	n/d	n/d	n/d	n/d	n/d	n/d
DM-500IS-C4H4S	n/d	45=140	45=100	45=135	n/d	n/d	n/d	n/d	45=150	n/d	45=50	45=180
DM-500IS-C6H5CH3	n/d	55=140	55=100	55=135	n/d	n/d	n/d	n/d	55=150	n/d	55=50	55=180
DM-500IS-C4H6O2	n/d	200=140	200=100	200=135	n/d	n/d	n/d	n/d	200=150	n/d	200=50	200=180
DM-500IS-C2H3CL	n/d	200=140	200=100	200=135	n/d	n/d	n/d	n/d	200=150	n/d	200=50	200=180

n/a = not applicable

n/d = no data

Interference Gas Table (page 3 of 5)

Model Number	C2H4	C2H4O	F2	CH2O	GeH4	N2H4	C-H's	C-H's (U)	H2	HBr	HCL	HCN	HF
DM-500IS-C2H3O	40=220	40=275	n/d	40=330	n/d	n/d	n/d	n/d	n/d	n/d	n/d	n/d	n/d
DM-500IS-C2H2	340=220	340=275	n/d	340=330	n/d	n/d	n/d	n/d	n/d	n/d	n/d	n/d	n/d
DM-500IS-C3H3N	75=220	75=275	n/d	75=330	n/d	n/d	n/d	n/d	n/d	n/d	n/d	n/d	n/d
DM-500IS-NH3 (-20°C)	n/d	n/d	n/d	n/d	1=0	n/d	%range=0	n/d	1%=0	n/d	5=0	10=0	4=0
DM-5011S-NH3 (-40°C)	n/d	n/d	n/d	n/d	1=0	n/d	%range=0	yes n/d	1000=35	n/d	yes n/d	10 = -18	n/d
DM-502IS-NH3 (CE)	100=0	n/d	n/d	n/d	n/d	n/d	n/d	n/d	200=4	n/d	5 = -3	10=0	n/d
DM-500IS-AsH3	n/d	n/d	n/d	n/d	1=0.4	n/d	%range=0	n/d	3000=0	n/d	5=0	10=0.1	4=0
DM-500IS-Br2	100=0	n/d	n/d	n/d	n/d	n/d	n/d	n/d	100=0	n/d	5=0	10=0	n/d
DM-500IS-C4H6	170=220	170=275	n/d	170=330	n/d	n/d	n/d	n/d	n/d	n/d	n/d	n/d	n/d
DM-500IS-CS2	140=220	140=275	n/d	140=330	n/d	n/d	n/d	n/d	n/d	n/d	n/d	n/d	n/d
DM-500IS-CO	100=<100	n/d	n/d	n/d	n/d	n/d	n/d	n/d	100 = <60	n/d	5=0	10 = -2	n/d
DM-500IS-COS	135=220	135=275	n/d	135=330	n/d	n/d	n/d	n/d	n/d	n/d	n/d	n/d	n/d
DM-500IS-CL2	100=0	n/d	n/d	n/d	n/d	n/d	n/d	n/d	100=0	n/d	5=0	10=0	n/d
DM-500IS-CLO2 (>10ppm)	100=0	n/d	n/d	n/d	n/d	n/d	n/d	n/d	100=0	n/d	5=0	10=0	n/d
DM-5011S-CLO2 (≤10ppm)	n/d	n/d	yes n/d	n/d	1=0	n/d	%range=0	n/d	1%=0	n/d	n/d	n/d	n/d
DM-500IS-B2H6	n/d	n/d	n/d	n/d	1=0.53	n/d	%range=0	n/d	3000=0	n/d	5=0	10=0.13	4=0
DM-500IS-C2H6S	150=220	150=275	n/d	150=330	n/d	n/d	n/d	n/d	n/d	n/d	n/d	n/d	n/d
DM-500IS-C3H5OCL	50=220	50=275	n/d	50=330	n/d	n/d	n/d	n/d	n/d	n/d	n/d	n/d	n/d
DM-500IS-C2H5OH	180=220	180=275	n/d	180=330	n/d	n/d	n/d	n/d	n/d	n/d	n/d	n/d	n/d
DM-500IS-C2H5SH	100=0	n/d	n/d	n/d	n/d	n/d	n/d	n/d	1%=<15	n/d	5=0	10=0	n/d
DM-500IS-C2H4	n/a	220=275	n/d	220=330	n/d	n/d	n/d	n/d	n/d	n/d	n/d	n/d	n/d
DM-500IS-C2H4O	275=200	n/a	n/d	275=330	n/d	n/d	n/d	n/d	n/d	n/d	n/d	n/d	n/d
DM-500IS-F2	n/d	n/d	n/a	n/d	n/d	n/d	%range=0	n/d	1%=0	n/d	5=0	1 = -3	3=0
DM-500IS-CH2O	330=220	330=275	n/d	n/a	n/d	n/d	n/d	n/d	n/d	n/d	n/d	n/d	n/d
DM-500IS-GeH4	n/d	n/d	n/d	n/d	n/a	n/d	%range=0	n/d	3000=0	n/d	5=0	10=1	4=0
DM-500IS-N2H4	n/d	n/d	n/d	n/d	n/d	n/d	%range=0	n/d	1000=0	n/d	5=0.1	n/d	3=0
DM-500IS-H2 (ppm)	100= ≈80	n/d	n/d	n/d	n/d	n/d	n/d	n/d	n/a	n/d	5=0	10 = ≈3	n/d
DM-5011S-H2 (LEL)	yes n/d	n/d	n/d	n/d	n/d	n/d	n/d	n/d	n/a	n/d	n/d	10=0	n/d
DM-500IS-HBr	n/d	n/d	n/d	n/d	n/d	n/d	%range=0	n/d	1%=0	n/a	1=1	15=1	3=0
DM-500IS-HCL	n/d	n/d	n/d	n/d	1=n/d	n/d	%range=0	n/d	1%=0	1=1	n/a	15=1	3=0
DM-500IS-HCN	n/d	n/d	n/d	n/d	n/d	n/d	%range=0	n/d	1000=0	n/d	5=0	n/a	3=0
DM-500IS-HF	n/d	n/d	yes n/d	n/d	1=0	n/d	%range=0	n/d	1%=0	n/d	5=3.3	n/d	n/a
DM-500IS-H2S	100=0	n/d	n/d	n/d	n/d	n/d	n/d	n/d	1%=<5	n/d	5=0	10=0	n/d
DM-500IS-CH3OH	415=220	415=275	n/d	415=330	n/d	n/d	n/d	n/d	n/d	n/d	n/d	n/d	n/d
DM-500IS-CH3SH	100=0	n/d	n/d	n/d	n/d	n/d	n/d	n/d	1%=<10	n/d	5=0	10=0	n/d
DM-500IS-NO	100=0	n/d	n/d	n/d	n/d	n/d	n/d	n/d	100=0	n/d	5=<1	10=0	n/d
DM-500IS-NO2	100=0	n/d	n/d	n/d	n/d	n/d	n/d	n/d	100=0	n/d	5=0	10=0	n/d
DM-500IS-O3	n/d	n/d	0.1=0.07	n/d	n/d	n/d	n/d	n/d	1%=0.003	n/d	10=0	10=0.33	5=0
DM-500IS-COCL2	n/d	n/d	n/d	n/d	n/d	n/d	%range=0	n/d	1%=0	n/d	5=0	5=0	3=0
DM-500IS-PH3	n/d	n/d	n/d	n/d	1=0.4	n/d	%range=0	n/d	3000=0	n/d	5=0	10=0.1	4=0
DM-500IS-SiH4	n/d	n/d	n/d	n/d	1=1.0	n/d	%range=0	n/d	3000=0	n/d	5=0	10=1	4=0
DM-500IS-SO2	100=0	n/d	n/d	n/d	n/d	n/d	n/d	n/d	100=0	n/d	5=0	10=<5	n/d
DM-500IS-C4H8S	1%=2.4	n/d	n/d	n/d	n/d	n/d	%range=0	yes n/d	0.1%=0.3	n/d	yes n/d	n/d	n/d
DM-500IS-C4H4S	45=220	45=275	n/d	45=330	n/d	n/d	n/d	n/d	n/d	n/d	n/d	n/d	n/d
DM-500IS-C6H5CH3	55=220	55=275	n/d	55=330	n/d	n/d	n/d	n/d	n/d	n/d	n/d	n/d	n/d
DM-500IS-C4H6O2	200=220	200=275	n/d	200=330	n/d	n/d	n/d	n/d	n/d	n/d	n/d	n/d	n/d
DM-500IS-C2H3CL	200=220	200=275	n/d	200=330	n/d	n/d	n/d	n/d	n/d	n/d	n/d	n/d	n/d

n/a = not applicable
n/d = no data

Interference Gas Table (page 4 of 5)

Model Number	HSe	H2S	I2	C3H8O	CH4	CH3OH	C4H8O	CH3SH	NO	N2	NO2	O3	COCL2
DM-500IS-C2H3O	n/d	n/d	n/d	n/d	n/d	40=415	n/d	40=275	n/d	n/d	n/d	n/d	n/d
DM-500IS-C2H2	n/d	n/d	n/d	n/d	n/d	340=415	n/d	340=275	n/d	n/d	n/d	n/d	n/d
DM-500IS -C3H3N	n/d	n/d	n/d	n/d	n/d	75=415	n/d	75=275	n/d	n/d	n/d	n/d	n/d
DM-500IS-NH3 (-20°C)	0.1=0	10=0	n/d	n/d	n/d	n/a	n/d	n/d	n/d	100%=0	n/d	n/d	n/d
DM-501IS-NH3 (-40°C)	n/d	14=18	n/d	n/d	n/d	yes n/d	n/d	n/d	n/d	100%=0	10 = -5	n/d	n/d
DM-502IS-NH3 (CE)	n/d	15=30	n/d	n/d	n/d	n/d	n/d	n/d	35=6	n/d	5 = -1	n/d	n/d
DM-500IS-AsH3	0.05=0.005	1=0	n/d	n/d	n/d	n/d	n/d	n/d	n/d	100%=0	n/d	n/d	n/d
DM-500IS-Br2	n/d	15 = -1.5	n/d	n/d	n/d	n/d	n/d	n/d	35=0	n/d	5 = ≈10	n/d	n/d
DM-500IS-C4H6	n/d	n/d	n/d	n/d	n/d	170=415	n/d	170=275	n/d	n/d	n/d	n/d	n/d
DM-500IS-CS2	n/d	n/d	n/d	n/d	n/d	140=415	n/d	140=275	n/d	n/d	n/d	n/d	n/d
DM-500IS-CO	n/d	15=<0.3	n/d	n/d	n/d	n/d	n/d	n/d	35=≤7	n/d	n/d	n/d	n/d
DM-500IS-COS	n/d	n/d	n/d	n/d	n/d	135=415	n/d	135=275	n/d	n/d	n/d	n/d	n/d
DM-500IS-CL2	n/d	15 = - 0.75	n/d	n/d	n/d	n/d	n/d	n/d	35=0	n/d	5 = ≈5	n/d	n/d
DM-500IS-CLO2 (>10ppm)	n/d	15=0.25	n/d	n/d	n/d	n/d	n/d	n/d	35=0	n/d	5=1.66	n/d	n/d
DM-501IS-CLO2 (≤10ppm)	n/d	10 = -0.015	n/d	n/d	n/d	n/d	n/d	n/d	n/d	n/d	yes n/d	yes n/d	n/d
DM-500IS-B2H6	0.05=0.006	1=0	n/d	n/d	n/d	n/d	n/d	n/d	n/d	100%=0	n/d	n/d	n/d
DM-500IS-C2H6S	n/d	n/d	n/d	n/d	n/d	150=415	n/d	1:15	n/d	n/d	n/d	n/d	n/d
DM-500IS-C3H5OCL	n/d	n/d	n/d	n/d	n/d	50=415	n/d	50=275	n/d	n/d	n/d	n/d	n/d
DM-500IS-C2H5OH	n/d	n/d	n/d	n/d	n/d	180=415	n/d	180=275	n/d	n/d	n/d	n/d	n/d
DM-500IS-C2H5SH	n/d	1:3	n/d	n/d	n/d	n/d	n/d	5=8	35=<6	n/d	5 = -1.5	n/d	n/d
DM-500IS-C2H4	n/d	n/d	n/d	n/d	n/d	220=415	n/d	220=275	n/d	n/d	n/d	n/d	n/d
DM-500IS-C2H4O	n/d	n/d	n/d	n/d	n/d	275=415	n/d	275=275	n/d	n/d	n/d	n/d	n/d
DM-500IS-F2	n/d	1 = -1.5	n/d	n/d	n/d	n/d	n/d	n/d	n/d	100%=0	1=0.05	0.1=0.2	n/d
DM-500IS-CH2O	n/d	n/d	n/d	n/d	n/d	330=415	n/d	330=275	n/d	n/d	n/d	n/d	n/d
DM-500IS-GeH4	0.05=0.005	1=0	n/d	n/d	n/d	n/d	n/d	n/d	n/d	100%=0	n/d	n/d	n/d
DM-500IS-N2H4	n/d	1=0.1	n/d	n/d	n/d	n/d	n/d	n/d	n/d	100%=0	1 = -0.25	0.1 = -0.1	n/d
DM-500IS-H2 (ppm)	n/d	15=<3	n/d	n/d	n/d	n/d	n/d	n/d	35= ≈10	n/d	5=0	n/d	n/d
DM-501IS-H2 (LEL)	n/d	n/d	n/d	yes n/d	1%=0	n/d	n/d	n/d	yes n/d	n/d	10=0	n/d	n/d
DM-500IS-HBr	0.1=0	10=2.75	n/d	n/d	n/d	n/d	n/d	n/d	n/d	100%=0	n/d	n/d	0.1=0
DM-500IS-HCL	0.1=0	10=2.75	n/d	n/d	n/d	n/d	n/d	n/d	n/d	100%=0	n/d	n/d	0.1=0
DM-500IS-HCN	n/d	10=0	n/d	n/d	n/d	n/d	n/d	n/d	n/d	100%=0	10 = -12	0.1=0	n/d
DM-500IS-HF	n/d	10=0	n/d	n/d	n/d	n/d	n/d	n/d	n/d	100%=0	10=0.1	n/d	n/d
DM-500IS-H2S	n/d	n/a	n/d	n/d	n/d	n/d	n/d	2:1	35=<2	n/d	5 = -0.5	n/d	n/d
DM-500IS-CH3OH	n/d	n/d	n/d	n/d	n/d	n/d	n/d	415=275	n/d	n/d	n/d	n/d	n/d
DM-500IS-CH3SH	n/d	1:2	n/d	n/d	n/d	n/d	n/d	n/a	35=<4	n/d	5 = -1.0	n/d	n/d
DM-500IS-NO	n/d	15= ≈5	n/d	n/d	n/d	n/d	n/d	n/d	100=0	n/d	5 =<1.5	n/d	n/d
DM-500IS-NO2	n/d	15 = - 0.75	n/d	n/d	n/d	n/d	n/d	n/d	35=0	n/d	n/a	n/d	n/d
DM-500IS-O3	n/d	1 = -.015	yes n/d	n/d	n/d	n/d	n/d	n/d	10=0	100%=0	1=0.7	n/a	n/d
DM-500IS-COCL2	n/d	1=0	n/d	n/d	n/d	n/d	n/d	n/d	n/d	100%=0	n/d	n/d	n/a
DM-500IS-PH3	0.05=0.005	1=0	n/d	n/d	n/d	n/d	n/d	n/d	n/d	100%=0	n/d	n/d	n/d
DM-500IS-SiH4	0.05=0.005	1=0	n/d	n/d	n/d	n/d	n/d	n/d	n/d	100%=0	n/d	n/d	n/d
DM-500IS-SO2	n/d	15=0	n/d	n/d	n/d	n/d	n/d	n/d	35=0	n/d	5 = ≈ -5	n/d	n/d
DM-500IS-C4H8S	n/d	20=0.3	n/d	n/d	100%=0	1300=64	n/d	n/d	10=7.5	100%=0	10=0.9	n/d	n/d
DM-500IS-C4H4S	n/d	n/d	n/d	n/d	n/d	45=415	n/d	45=275	n/d	n/d	n/d	n/d	n/d
DM-500IS-C6H5CH3	n/d	n/d	n/d	n/d	n/d	55=415	n/d	55=275	n/d	n/d	n/d	n/d	n/d
DM-500IS-C4H6O2	n/d	n/d	n/d	n/d	n/d	200=415	n/d	200=275	n/d	n/d	n/d	n/d	n/d
DM-500IS-C2H3CL	n/d	n/d	n/d	n/d	n/d	200=415	n/d	200=275	n/d	n/d	n/d	n/d	n/d

n/a = not applicable

n/d = no data

Interference Gas Table (page 5 of 5)

Model Number	PH3	PF3	SiH4	Si	SiF4	SO2	C4H8S	C4H4S	C6H5CH3	WF6	C4H6O2	C2H3CL	C2H5SH	C6H5CH3
DM-500IS-C2H3O	n/d	n/d	n/d	n/d	n/d	n/d	n/d	40=45	n/d	n/d	40=200	40=200	n/d	40=55
DM-500IS-C2H2	n/d	n/d	n/d	n/d	n/d	n/d	n/d	340=45	n/d	n/d	340=200	340=200	n/d	340=55
DM-500IS-C3H3N	n/d	n/d	n/d	n/d	n/d	n/d	n/d	75=45	n/d	n/d	75=200	75=200	n/d	75=55
DM-500IS-NH3 (-20°C)	300=0	n/d	n/d	n/d	n/d	2=0	n/d	n/d	n/d	n/d	n/d	n/d	n/d	n/d
DM-501IS-NH3 (-40°C)	0.3=0	n/d	n/d	n/d	n/d	yes n/d	n/d	n/d	n/d	n/d	n/d	n/d	n/d	n/d
DM-502IS-NH3 (CE)	n/d	n/d	n/d	n/d	n/d	5= -0.5	n/d	n/d	n/d	n/d	n/d	n/d	n/d	n/d
DM-500IS-AsH3	0.1-0.11	n/d	1=0.56	n/d	n/d	2=0	n/d	n/d	n/d	n/d	n/d	n/d	n/d	n/d
DM-500IS-Br2	n/d	n/d	n/d	n/d	n/d	5= -0.1	n/d	n/d	n/d	n/d	n/d	n/d	n/d	n/d
DM-500IS-C4H6	n/d	n/d	n/d	n/d	n/d	n/d	n/d	170=45	n/d	n/d	170=200	170=200	n/d	170=55
DM-500IS-CS2	n/d	n/d	n/d	n/d	n/d	n/d	n/d	140=45	n/d	n/d	140=200	140=200	n/d	140=55
DM-500IS-CO	n/d	n/d	n/d	n/d	n/d	5=0	n/d	n/d	n/d	n/d	n/d	n/d	n/d	n/d
DM-500IS-COS	n/d	n/d	n/d	n/d	n/d	n/d	n/d	135=45	n/d	n/d	135=200	135=200	n/d	135=55
DM-500IS-CL2	n/d	n/d	n/d	n/d	n/d	5= 0.05	n/d	n/d	n/d	n/d	n/d	n/d	n/d	n/d
DM-500IS-CLO2 (>10ppm)	n/d	n/d	n/d	n/d	n/d	5=-0.016	n/d	n/d	n/d	n/d	n/d	n/d	n/d	n/d
DM-501IS-CLO2 (≤10ppm)	n/d	n/d	n/d	n/d	n/d	n/d	n/d	n/d	n/d	n/d	n/d	n/d	n/d	n/d
DM-500IS-B2H6	0.1=0.14	n/d	1=0.72	n/d	n/d	2=0	n/d	n/d	n/d	n/d	n/d	n/d	n/d	n/d
DM-500IS-C2H6S	n/d	n/d	n/d	n/d	n/d	n/d	n/d	150=45	n/d	n/d	150=200	150=200	n/d	150=55
DM-500IS-C3H5OCL	n/d	n/d	n/d	n/d	n/d	n/d	n/d	50=45	n/d	n/d	50=200	50=200	n/d	50=55
DM-500IS-C2H5OH	n/d	n/d	n/d	n/d	n/d	n/d	n/d	180=45	n/d	n/d	180=200	180=200	n/d	180=55
DM-500IS-C2H5SH	n/d	n/d	n/d	n/d	n/d	5=<3	n/d	n/d	n/d	n/d	n/d	n/d	n/d	n/d
DM-500IS-C2H4	n/d	n/d	n/d	n/d	n/d	n/d	n/d	220=45	n/d	n/d	220=200	220=200	n/d	220=55
DM-500IS-C2H4O	n/d	n/d	n/d	n/d	n/d	n/d	n/d	275=45	n/d	n/d	275=200	275=200	n/d	275=55
DM-500IS-F2	n/d	n/d	n/d	n/d	n/d	2=0	n/d	n/d	n/d	n/d	n/d	n/d	n/d	n/d
DM-500IS-CH2O	n/d	n/d	n/d	n/d	n/d	n/d	n/d	330=45	n/d	n/d	330=200	330=200	n/d	330=55
DM-500IS-GeH4	0.1=0.13	n/d	n/d	n/d	n/d	2=0	n/d	n/d	n/d	n/d	n/d	n/d	n/d	n/d
DM-500IS-N2H4	0.3=0.1	n/d	n/d	n/d	n/d	2=0	n/d	n/d	n/d	n/d	n/d	n/d	n/d	n/d
DM-500IS-H2 (ppm)	n/d	n/d	n/d	n/d	n/d	5=0	n/d	n/d	n/d	n/d	n/d	n/d	n/d	n/d
DM-501IS-H2 (LEL)	n/d	n/d	n/d	n/d	n/d	2=0	n/d	n/d	n/d	n/d	n/d	n/d	n/d	n/d
DM-500IS-HBr	0.1=0.3	n/d	n/d	n/d	n/d	5=2.5	n/d	n/d	n/d	n/d	n/d	n/d	n/d	n/d
DM-500IS-HCL	0.1=0.3	n/d	n/d	n/d	n/d	5=2.5	n/d	n/d	n/d	n/d	n/d	n/d	n/d	n/d
DM-500IS-HCN	0.3=0	n/d	n/d	n/d	n/d	2=0	n/d	n/d	n/d	n/d	n/d	n/d	n/d	n/d
DM-500IS-HF	0.1=0	yes n/d	n/d	n/d	3=4 (theor.)	yes n/d	n/d	n/d	n/d	yes n/d	n/d	n/d	n/d	n/d
DM-500IS-H2S	n/d	n/d	n/d	n/d	n/d	5=<1	n/d	n/d	n/d	n/d	n/d	n/d	3=1	n/d
DM-500IS-CH3OH	n/d	n/d	n/d	n/d	n/d	n/d	n/d	415=45	n/d	n/d	415=200	415=200	n/d	415=55
DM-500IS-CH3SH	n/d	n/d	n/d	n/d	n/d	5=<2	n/d	n/d	n/d	n/d	n/d	n/d	2=1	n/d
DM-500IS-NO	n/d	n/d	n/d	n/d	n/d	5=0	n/d	n/d	n/d	n/d	n/d	n/d	n/d	n/d
DM-500IS-NO2	n/d	n/d	n/d	n/d	n/d	5= -0.025	n/d	n/d	n/d	n/d	n/d	n/d	n/d	n/d
DM-500IS-O3	0.3=0.03	n/d	1=0.015	n/d	n/d	2=0	n/d	n/d	n/d	n/d	n/d	n/d	n/d	n/d
DM-500IS-COCL2	0.3=0	n/d	n/d	n/d	n/d	2=0	n/d	n/d	n/d	n/d	n/d	n/d	n/d	n/d
DM-500IS-PH3	n/a	n/d	1=0.56	n/d	n/d	2=0	n/d	n/d	n/d	n/d	n/d	n/d	n/d	n/d
DM-500IS-SiH4	0.1=0.13	n/a	n/d	n/d	n/d	2=0	n/d	n/d	n/d	n/d	n/d	n/d	n/d	n/d
DM-500IS-SO2	n/d	n/d	n/d	n/d	n/d	n/a	n/d	n/d	n/d	n/d	n/d	n/d	n/d	n/d
DM-500IS-C4H8S	n/d	n/d	n/d	n/d	n/d	2=0.6	n/a	n/d	n/d	n/d	n/d	n/d	n/d	n/a
DM-500IS-C4H4S	n/d	n/d	n/d	n/d	n/d	n/d	n/d	n/a	n/d	n/d	45=200	45=200	n/d	45=55
DM-500IS-C6H5CH3	n/d	n/d	n/d	n/d	n/d	n/d	n/d	55=45	n/d	n/d	55=200	n/d	n/d	n/d
DM-500IS-C4H6O2	n/d	n/d	n/d	n/d	n/d	n/d	n/d	200=45	n/d	n/d	n/a	200=200	n/d	200=55
DM-500IS-C2H3CL	n/d	n/d	n/d	n/d	n/d	n/d	n/d	200=45	n/d	n/d	200=200	n/a	n/d	200=55

n/a = not applicable

n/d = no data

4.0 Specifications

Method of Detection

Electrochemical Cell

Electrical Classification

CSA-NRTL (US OSHA) approved* Class 1; Groups B, C, D; Div. 1.

Input Voltage

11.5-28 VDC

Power Consumption

Normal operation = 29.5 mA @ 24VDC

Maximum 50mA @ 24VDC

Maximum 70mA @ 11.5VDC

Output

Linear 4-20 mA DC

Repeatability

± 2% FS

Table 2 Sensor cell specifications

Model Number	Gas Name	Response Time(seconds)	Span Drift	Temperature Range °C	Temperature Range °F	Humidity Range %	Sensor Cell Warranty
DM-500IS-C2H3O	Acetaldehyde	T90 <140	<5% signal loss/year	-20 to +50	-4 to +122	15 to 90	2 years
DM-500IS-C2H2	Acetylene	T90 <140	<5% signal loss/year	-20 to +50	-4 to +122	15 to 90	2 years
DM-500IS-C3H3N	Acrylonitrile	T90 <140	<5% signal loss/year	-20 to +50	-4 to +122	15 to 90	2 years
DM-500IS-NH3 (-20°C)	Ammonia	T90 <60	<1% signal loss/month	-20 to +40	-4 to +104	10 to 95	2 years
DM-501IS-NH3 (-40°C)	Ammonia	T90 <90	<2% signal loss/month	-40 to +40	-40 to +104	5 to 95	2 years
DM-502IS-NH3 (CE)	Ammonia	T90 <90	<2% signal loss/month	-40 to +50	-40 to +122	15 to 90	2 years
DM-500IS-AsH3	Arsine	T90 <60	<5% signal loss/month	-20 to +40	-4 to +104	20 to 95	1-1/2 years
DM-500IS-Br2	Bromine	T90 <60	<2% signal loss/month	-20 to +50	-4 to +122	15 to 90	2 years
DM-500IS-C4H6	Butadiene	T90 <140	<5% signal loss/year	-20 to +50	-4 to +122	15 to 90	2 years
DM-500IS-CS2	Carbon Disulfide	T90 <140	<5% signal loss/year	-20 to +50	-4 to +122	15 to 90	2 years
DM-500IS-CO	Carbon Monoxide	T90 ≤30	<5% signal loss/year	-40 to +50	-40 to +122	15 to 90	3 years
DM-500IS-COS	Carbonyl Sulfide	T90 <140	<5% signal loss/year	-20 to +50	-4 to +122	15 to 90	2 years
DM-500IS-CL2	Chlorine	T90 <60	<2% signal loss/month	-20 to +50	-4 to +122	15 to 90	2 years
DM-500IS-CLO2 (>10ppm)	Chlorine Dioxide	T90 <60	<2% signal loss/month	-20 to +50	-4 to +122	15 to 90	2 years
DM-501IS-CLO2 (≤10ppm)	Chlorine Dioxide	T90 <120	<1% signal loss/month	-20 to +40	-4 to +104	10 to 95	2 years
DM-500IS-B2H6	Diborane	T90 <60	<5% signal loss/month	-20 to +40	-4 to +104	20 to 95	1-1/2 years
DM-500IS-C2H6S	Dimethyl Sulfide	T90 <140	<5% signal loss/year	-20 to +50	-4 to +122	15 to 90	2 years
DM-500IS-C3H5OCL	Epichlorohydrin	T90 <140	<5% signal loss/year	-20 to +50	-4 to +122	15 to 90	2 years
DM-500IS-C2H5OH	Ethanol	T90 <140	<5% signal loss/year	-20 to +50	-4 to +122	15 to 90	2 years
DM-500IS-C2H5SH	Ethyl Mercaptan	T90 <45	<2% signal loss/month	-40 to +50	-40 to +122	15 to 90	2 years
DM-500IS-C2H4	Ethylene	T90 <140	<5% signal loss/year	-20 to +50	-4 to +122	15 to 90	2 years
DM-500IS-C2H4O	Ethylene Oxide	T90 <140	<5% signal loss/year	-20 to +50	-4 to +122	15 to 90	2 years
DM-500IS-F2	Fluorine	T90 <80	<5% signal loss/year	-10 to +40	+14 to +104	10 to 95	1-1/2 years
DM-500IS-CH2O	Formaldehyde	T90 <140	<5% signal loss/year	-20 to +50	-4 to +122	15 to 90	2 years
DM-500IS-GeH4	Germane	T90 <60	<1% signal loss/month	-20 to +40	-4 to +104	20 to 95	1-1/2 years
DM-500IS-N2H4	Hydrazine	T90 <120	<5% signal loss/month	-10 to +40	+14 to +104	10 to 95	1 year
DM-500IS-H2 (ppm)	Hydrogen	T90 ≤30	<2% signal loss/month	-20 to +50	-4 to +122	15 to 90	2 years
DM-501IS-H2 (LEL)*	Hydrogen	T90 <60	<2% signal loss/month	-40 to +40	-40 to +104	5 to 95	2 years
DM-500IS-HBr	Hydrogen Bromide	T90 <70	<3% signal loss/month	-20 to +40	-4 to +104	10 to 95	1-1/2 years
DM-500IS-HCL	Hydrogen Chloride	T90 <70	<2% signal loss/month	-20 to +40	-4 to +104	10 to 95	1-1/2 years
DM-500IS-HCN	Hydrogen Cyanide	T90 <40	<5% signal loss/month	-40 to +40	-40 to +104	5 to 95	2 years
DM-500IS-HF	Hydrogen Fluoride	T90 <90	<10% signal loss/month	-20 to +35	-4 to +95	10 to 80	1-1/2 years
DM-500IS-H2S	Hydrogen Sulfide	T90 ≤30	<2% signal loss/month	-40 to +50	-40 to +122	15 to 90	2 years
DM-500IS-CH3OH	Methanol	T90 <140	<5% signal loss/year	-20 to +50	-4 to +122	15 to 90	2 years
DM-500IS-CH3SH	Methyl Mercaptan	T90 <45	<2% signal loss/month	-40 to +50	-40 to +122	15 to 90	2 years
DM-500IS-NO	Nitric Oxide	T90 ≤10	<2% signal loss/month	-20 to +50	-4 to +122	15 to 90	3 years
DM-500IS-NO2	Nitrogen Dioxide	T90 <40	<2% signal loss/month	-20 to +50	-4 to +122	15 to 90	2 years
DM-500IS-O3	Ozone	T90 <120	<1% signal loss/month	-10 to +40	+14 to +104	10 to 95	2 years
DM-500IS-COCL2	Phosgene	T90 <120	<1% signal loss/month	-20 to +40	-4 to +104	10 to 95	1-1/2 years
DM-500IS-PH3	Phosphine	T90 <30	<1% signal loss/month	-20 to +40	-4 to +104	20 to 95	1-1/2 years
DM-500IS-SiH4	Silane	T90 <60	<1% signal loss/month	-20 to +40	-4 to +104	20 to 95	1-1/2 years

DM-500IS-SO2	Sulfur Dioxide	T90 ≤20	<2% signal loss/month	-20 to +50	-4 to +122	15 to 90	2 years
DM-500IS-C4H8S	Tetrahydrothiophene	T90 <30	<2% signal loss/month	-10 to +40	+14 to +104	10 to 95	2 years
DM-500IS-C4H4S	Thiophane	T90 <140	<5% signal loss/year	-20 to +50	-4 to +122	15 to 90	2 years
DM-500IS-C6H5CH3	Toluene	T90 <140	<5% signal loss/year	-20 to +50	-4 to +122	15 to 90	2 years
DM-500IS-C4H6O2	Vinyl Acetate	T90 <140	<5% signal loss/year	-20 to +50	-4 to +122	15 to 90	2 years
DM-500IS-C2H3CL	Vinyl Chloride	T90 <140	<5% signal loss/year	-20 to +50	-4 to +122	15 to 90	2 years

*LEL range H2 is not CSA approved.

5.0 Installation

Optimum performance of ambient air/gas sensor devices is directly relative to proper location and installation practice.

5.1 Field Wiring Table (4-20 mA output)

Detcon Model DM-500IS toxic gas sensor assemblies require three conductor connection between power supplies and host electronic controllers. Wiring designators are + (DC), - (DC), and mA (sensor signal). Maximum single conductor resistance between sensor and controller is 10 ohms. Maximum wire size for termination in the sensor assembly terminal board is 14 gauge.

AWG	Meters	Feet
18	360	1200
16	600	2000
14	900	3000

Table 3 Field wiring Table

Note1: This wiring table is based on stranded tinned copper wire and is designed to serve as a reference only.

Note2: Shielded cable may be required in installations where cable trays or conduit runs include high voltage lines or other sources of induced interference.

Note3: The supply of power must be from an isolating source with over-current protection as follows:

AWG	Over-current Protection	AWG	Over-current Protection
22	3A	16	10A
20	5A	14	20A
18	7A	12	25A

Table 4 Over-current Protection per AWG

5.2 Sensor Location

Selection of sensor location is critical to the overall safe performance of the product. Five factors play an important role in selection of sensor locations:

- 1) Density of the gas to be detected
- 2) Most probable leak sources within the industrial process
- 3) Ventilation or prevailing wind conditions
- 4) Personnel exposure
- 5) Maintenance access

Density - Placement of sensors relative to the density of the target gas is such that sensors for the detection of heavier than air gases should be located within 2-4 feet of grade as these heavy gases will tend to settle in low lying areas. For gases lighter than air, sensor placement should be 4-8 feet above grade in open areas or in pitched areas of enclosed spaces.

Leak Sources - Most probable leak sources within an industrial process include flanges, valves, and tubing connections of the sealed type where seals may either fail or wear. Other leak sources are best determined by facility engineers with experience in similar processes.

Ventilation - Normal ventilation or prevailing wind conditions can dictate efficient location of gas sensors in a manner where the migration of gas clouds is quickly detected.

Personnel Exposure - The undetected migration of gas clouds should not be allowed to approach concentrated personnel areas such as control rooms, maintenance or warehouse buildings. A more general and applicable thought toward selecting sensor location is combining leak source and perimeter protection in the best possible configuration.

Maintenance Access

Consideration should be given to easy access by maintenance personnel as well as the consequences of close proximity to contaminants that may foul the sensor prematurely.

Note: In all installations, the sensor element in SS housing points down relative to grade (Figure 7). Improper sensor orientation may result in false reading and permanent sensor damage.

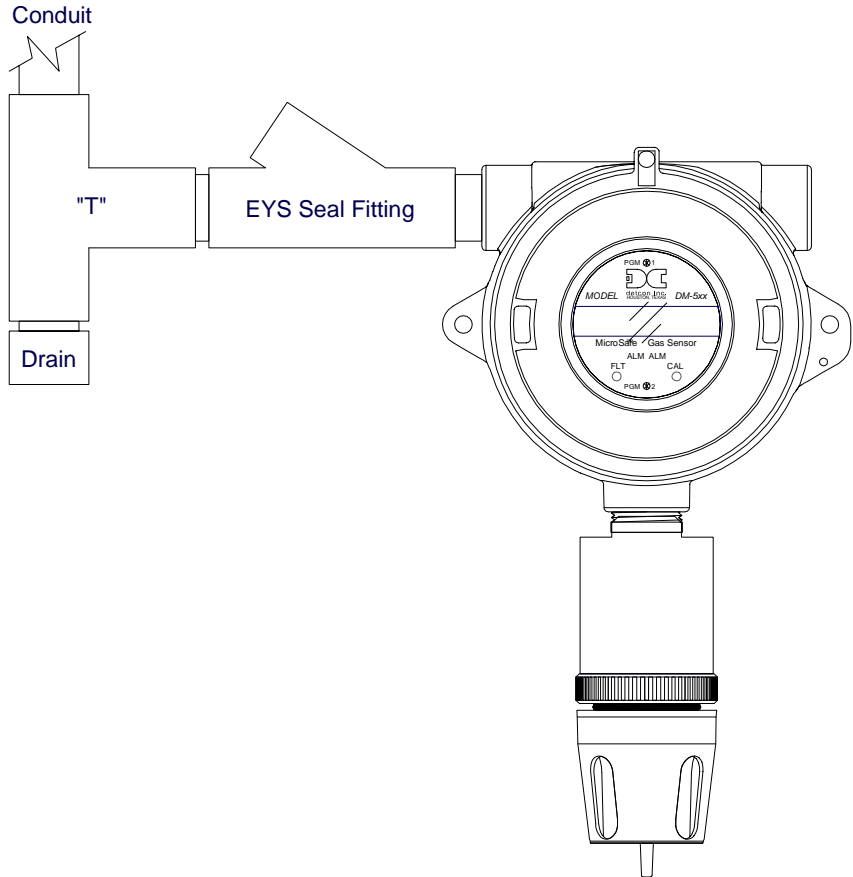

Figure 7 Typical Installation

5.3 Local Electrical Codes

Sensor and transmitter assemblies should be installed in accordance with all local electrical codes. Use appropriate conduit seals. Drains & breathers are recommended. The sensor assemblies are CSA-NRTL approved for Class I; Groups B, C, D; Div. 1 environments.

5.4 Installation Procedure

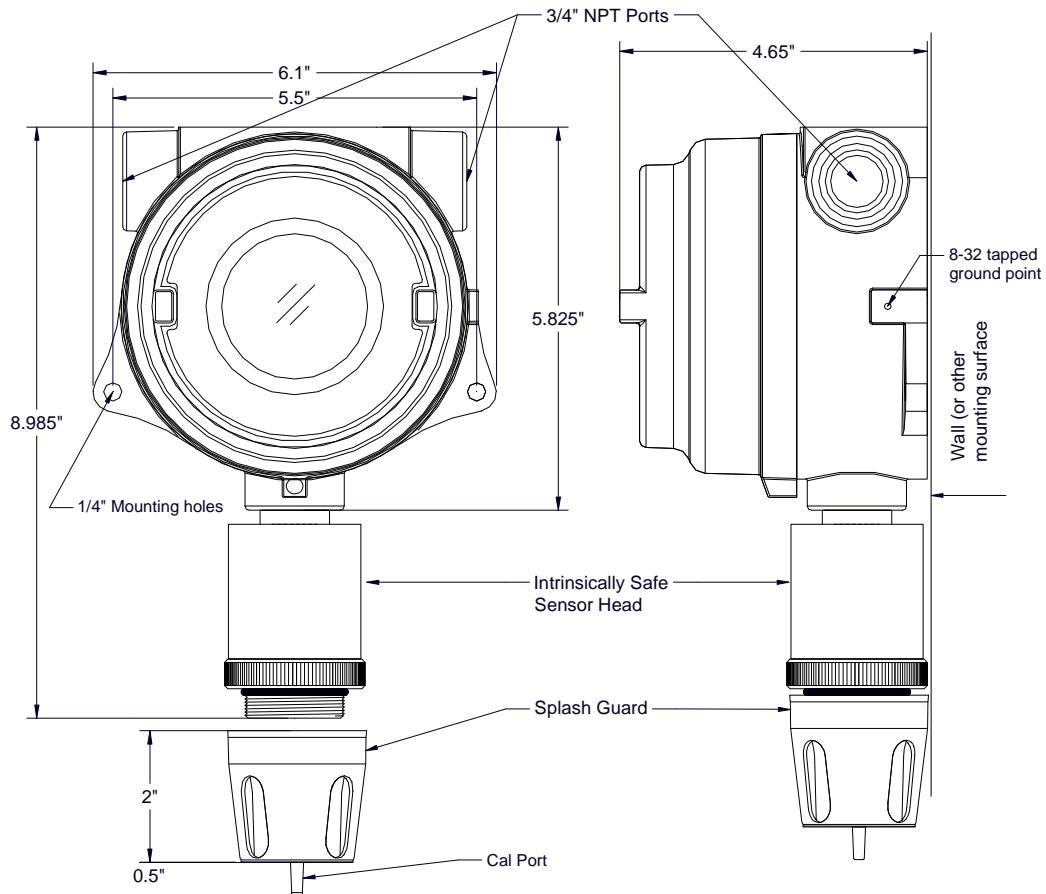

Figure 8 Typical Outline and Mounting Dimensions

- a. Securely mount the sensor junction box in accordance with recommended practice. See dimensional drawing (Figure 8).
- b. Remove the junction box cover and un-plug the control circuit by grasping the two thumb screws and pulling outward. Observing correct polarity, connect the loop power field wiring to the terminals labeled “+” and “-” 4-20 mA. (Figure 9) Reinstall cover.

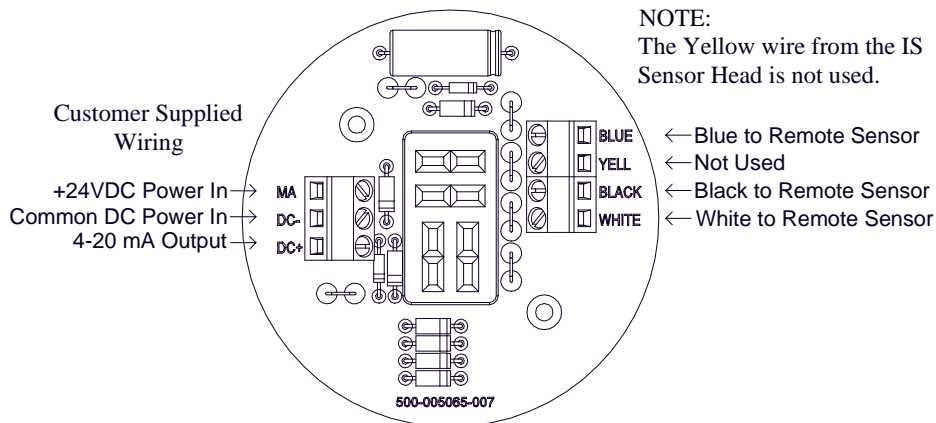

Figure 9 Sensor wiring

5.5 Remote Mounting Applications

Some sensor mounting applications require that the gas sensor head be remotely mounted away from the sensor transmitter. This is usually true in instances where the gas sensor head must be mounted in a location that is difficult to access. Such a location creates problems for maintenance and calibration activities. Detcon provides the DM-500IS sensor in a remote-mount configuration in which the sensor (Model DM-500IS-RS) and the transmitter (Model DM-500IS-RT) are provided in their own conduit housing and are interfaced together with a three conductor shielded cable. Sensor can be separate from transmitter up to 50 feet using shielded twisted pair cable. Reference Figure 10 for wiring diagram.

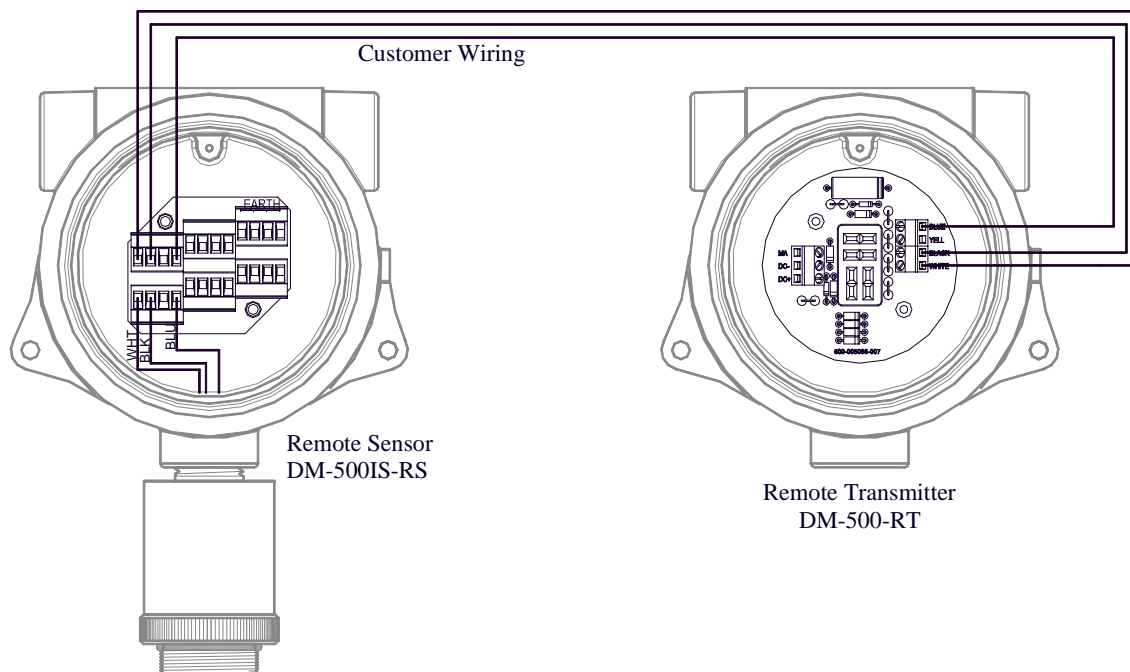

Figure 10 Remote wiring diagram

6.0 Startup

Upon completion of all mechanical mounting and termination of all field wiring, apply system power and observe the following normal conditions:

- a. DM-5xxIS “Fault” LED is off.
- b. A temporary upscale reading will occur as the sensor powers up. This upscale reading will clear to “0” ppm within approximately 30 minutes of turn-on, assuming there is no gas in the area of the sensor.

NOTE: Zero Clearing with Biased Cells

Some electrochemical sensors are biased with an excitation voltage. When power to the sensor is lost, this bias voltage slowly decays. When power is restored after long periods (multiple hours) of being unpowered, a surge in sensor output takes place and a long and slow re-establishing of the sensor’s zero baseline takes place. This re-stabilization time may range from 1 hour to 24 hours depending on the type of sensor and range of operation. The sensor types that this applies to are the following: HCl, NO, plus all the VOC sensors, C2H30, C2H2, C3H3N, C4H6, CS2, COS, C2H6S, C3H5OCL, C2H5OH, C2H4, C2H4O, CH2O, CH3OH, C4H4S, C4H6O2, C6H5CH3 and C2H3CL.

If this characteristic is problematic for your specific application, a battery backup or uninterruptible power supply is recommended.

6.1 Initial Operational Tests

After a warm up period has been allowed for, the sensor should be checked to verify sensitivity to its target gas.

Material Requirements

- Detcon PN 943-000006-132 Calibration Adapter
 - Span gas containing the target gas in air or nitrogen. It is recommended that the target gas concentration be 50% of scale at a controlled flow rate of 500 ml/min. For example, a Model DM-500IS-H2S sensor in the range 0-100ppm would require a test gas of 50ppm H2S. For a sensor with a range of 0-10ppm a test gas of 5ppm is recommended, etc.
- a. Attach the calibration adapter to the sensor housing. Apply the test gas at a controlled flow rate of 500 ml/m. Observe that the display increases to a level of 20% of range or higher.
 - b. Remove the test gas and observe that the display decreases to “**0 PPM**”.

Initial operational tests are complete. Detcon toxic gas sensors are pre-calibrated prior to shipment and will, in most cases, not require significant adjustment on start up. However, it is recommended that a complete calibration test and adjustment be performed within 24 hours of installation. Refer to calibration instructions in Section 9.0.

7.0 Operating Software & Magnetic Interface

Operating software is menu listed with operator interface via the two magnetic program switches located under the face plate. The two switches are referred to as “PGM 1” and “PGM 2”. The menu list consists of 3 items which include submenus as indicated below. (Note: see section 8.0 for a complete software flow chart.)

1. Normal Operation
 - a) Current Status
2. Calibration Mode
 - a) Zero
 - b) Span
3. Program Menu
 - a) View Program Status
 - b) Set Calibration Level

7.1 Normal Operation

In normal operation, the display tracks the current status of the sensor and gas concentration and appears as: “0 PPM xxx” (the “xxx” is the abbreviated gas type, i.e. “0 PPM H2S”). The mA current output corresponds to the monitoring level of 0-100% of range = 4-20 mA.

7.2 Calibration Mode

Calibration mode allows for sensor zero and span adjustments. “1-ZERO 2-SPAN”

7.2.1 Zero Adjustment

Zero is set in ambient air with no target gas present or with zero gas applied to the sensor. “AUTO ZERO”

7.2.2 Span Adjustment

Span adjustment is performed with a target gas concentration of 50% of range in air or nitrogen. Span gas concentrations other than 50% of range may be used. Refer to section 7.3.2 for details. “AUTO SPAN”

7.3 Program Mode

The program mode provides a program status menu (View Program Status) to check operational parameters. It also allows for the adjustment of the calibration gas level setting.

7.3.1 Program Status

The program status scrolls through a menu that displays:

- The software version number.
- Range is ###
- The calibration gas level setting. The menu item appears as: “CalLevel @ xxPPM”
- The estimated remaining sensor life. The menu item appears as: “SENSOR LIFE 100%”

7.3.2 Calibration Level Adjustment

The calibration level is adjustable from 10% to 90% of range. The menu item appears as: “CalLevel @ ##PPM”

7.4 Programming Magnet Operating Instructions

Operator interface to MicroSafe™ gas detection products is via magnetic switches located behind the transmitter face plate. DO NOT remove the glass lens cover to calibrate or change programming parameters. Two switches labeled “PGM 1” and “PGM 2” allow for complete calibration and programming without removing the enclosure cover, thereby eliminating the need for area de-classification or the use of hot permits.



Figure 11 Programming magnet

A magnetic programming tool (see Figure 11) is used to operate the switches. Switch action is defined as momentary contact, 3-second hold, and 30-second hold. In momentary contact use, the programming magnet is waved over a switch location. In 3 second hold, the programming magnet is held in place over a switch location for 3 or more seconds. In 30 second hold, the programming magnet is held in place over a switch location for 30 or more seconds. Three and thirty second hold is used to enter or exit calibration and program menus while momentary contact is used to make adjustments. The location of “PGM 1” and “PGM 2” are shown in Figure 12.

NOTE: If, after entering the calibration or program menus, there is no interaction with the menu items for more than 30 seconds, the sensor will return to its normal operating condition.

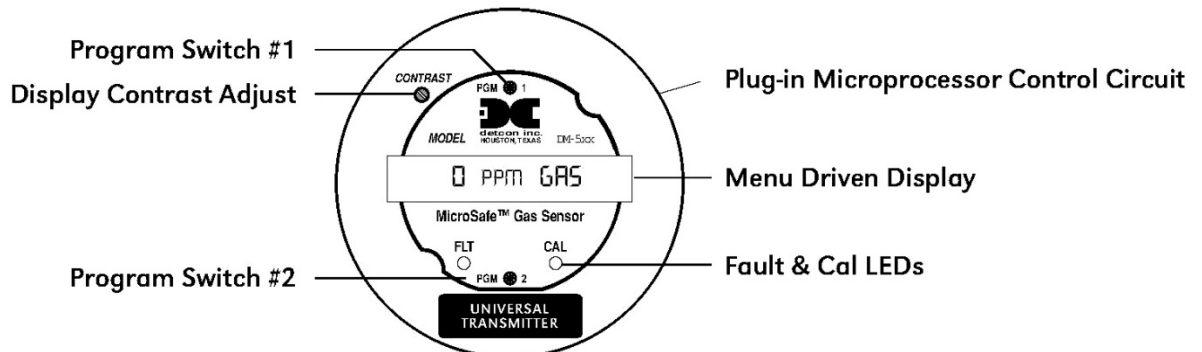

Figure 12 Programming Switch locations

8.0 Software Flow Chart

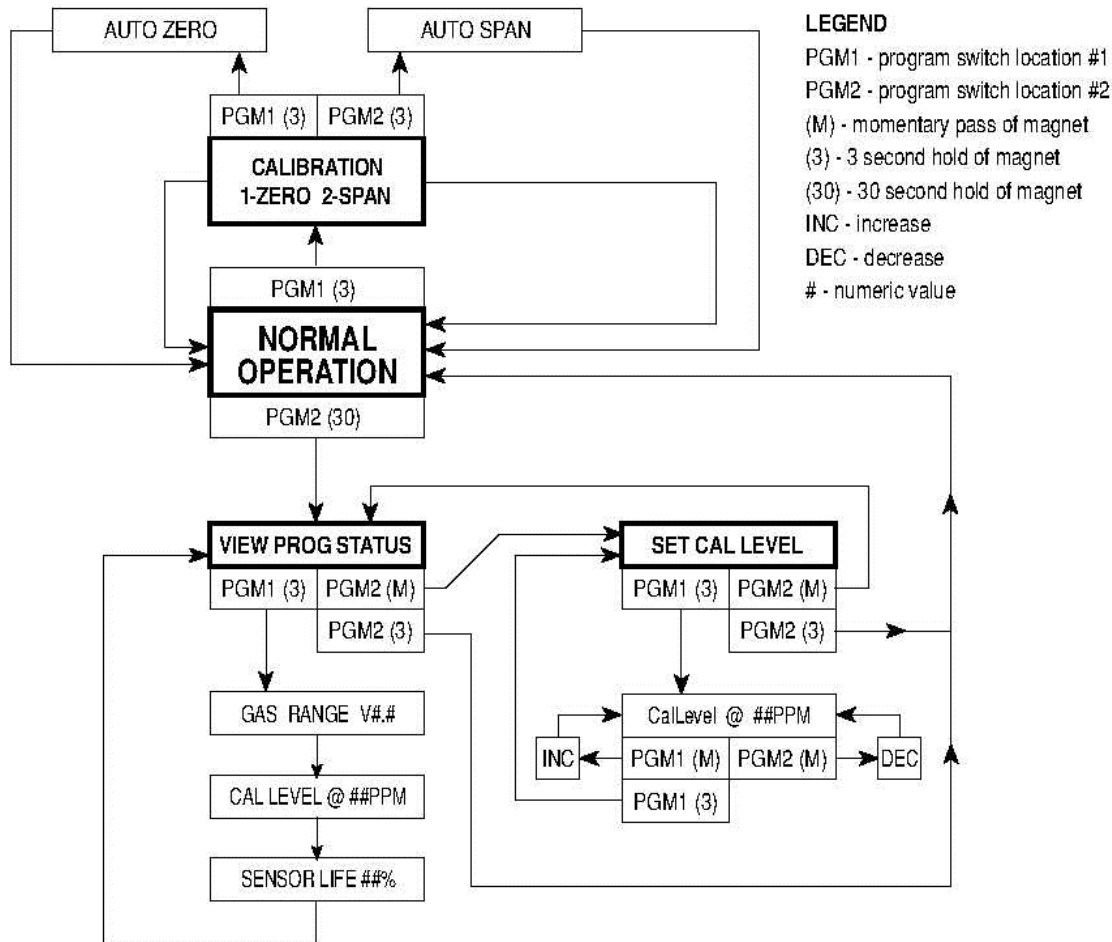

Figure 13 Software Flow Chart

9.0 Calibration

Material Requirements

- Detcon PN 327-000000-000 MicroSafe™ Programming Magnet
- Detcon PN 943-000006-132 Calibration Adapter
- Span gas containing the target gas in air or nitrogen. The target gas concentration is recommended at 50% of range (which is the factory default) at a controlled flow rate of 500 ml/min. Example: for a Model DM-500IS-H₂S sensor with a range of 0-100ppm, a test gas of 50 ppm is recommended. For a sensor with a range of 0-10 ppm a test gas of 5 ppm is recommended, etc. Other concentrations can be used as long as they fall within 10% to 90% of range. See section 9.2 for details. Reference section 10 -2) -b) if you do not know the sensor target gas or range of detection.

9.1 Calibration Procedure – Zero

NOTE: Before performing a zero calibration, be sure there is no background gas present or apply a zero gas standard prior to performing zero calibration.

- a. Enter the calibration menu by holding the programming magnet stationary over “PGM 1” (see Figure 12) for 3 seconds until the display reads “**1-ZERO 2-SPAN**” then withdraw the magnet. Note that the “CAL” LED is on.
- b. Next, enter the zero menu by holding the magnet stationary over “PGM 1” for 3 seconds until the display reads: “**SETTING ZERO**”, then withdraw the magnet. The sensor has now entered the auto zero mode. When it is complete the display will read “**ZERO COMPLETE**” for 5 seconds and then return to the normal operations menu reading “**(0 PPM)**”.

Zero calibration is complete.

9.2 Calibration Procedure – Span

CAUTION: Verification of the correct calibration gas level setting and calibration span gas concentration is required before “span” calibration. These two numbers must be equal.

Calibration consists of entering the calibration function and following the menu-displayed instructions. The display will ask for the application of span gas in a specific concentration. This concentration must be equal to the calibration gas level setting. The factory default setting for span gas concentration is 50% of range. In this instance, a span gas containing a concentration equal to 50% of range is required. If a span gas containing 50% of range is not available, other concentrations may be used as long as they fall within 10% to 90% of range. However, any alternate span gas concentration value must be programmed via the calibration gas level menu before proceeding with span calibration. Follow the instructions below for span calibration.

- a. Verify the current calibration gas level setting as indicated by the programming status menu. To do this, follow the instructions in section 11.0 and make note of the setting found in section 10- 2) -c). The item appears as “**GasLevel @ xxPPM**”.
- b. If the calibration gas level setting is equal to your calibration span gas concentration, proceed to item “f”. If not, adjust the calibration gas level setting so that it is equal to your calibration span gas concentration, as instructed in items “c” through “e”.
- c. Enter the programming menu by holding the programming magnet stationary over “PGM 2” for 30 seconds until the display reads “**VIEW PROG STATUS**” then withdraw the magnet. At this point you can scroll through the programming menu by momentarily waving the programming magnet over “PGM 1” or “PGM 2”. The menu options are: View Program Status, and Set Cal Level.
- d. From the programming menu scroll to the calibration level listing. The menu item appears as: “**SET CAL LEVEL**”. Enter the menu by holding the programming magnet stationary over “PGM 1” for 3 seconds until the display reads “**CalGas @ ##PPM**”, then withdraw the magnet. Use the programming magnet to make an adjustment to “PGM 1” to increase or “PGM 2” to decrease the display reading until the reading is equal to the desired calibration span gas concentration. Exit to the programming menu by holding the programming magnet over “PGM1” for 3 seconds.
- e. Exit back to normal operation by holding the programming magnet over “PGM 2” for 3 seconds, or automatically return to normal operation in 30 seconds.
- f. From the calibration menu “**1-ZERO 2-SPAN**” (section 9.1a) proceed into the span adjust function by holding the programming magnet stationary over “PGM 2” for 3 seconds then withdraw the programming magnet. At this point the display will ask for the application of the target gas and

concentration. The display reads “**APPLY xxPPM xxx**” The x’s here will indicate the actual concentration requested.

- g. Apply the calibration test gas at a flow rate of 500 milliliters per minute. As the sensor signal changes, the display will change to “**AutoSpan xxPPM**”. The “xx” part of the reading indicates the actual gas reading which will increase until the sensor stabilizes. When the sensor signal is stable it will auto span to the correct ppm reading and the display will change to “**SPAN COMPLETE**” for 3 seconds, then to “**SENSOR LIFE: xxx%**” and then “**REMOVE GAS**”. Remove the gas. When the signal level has fallen below 10% of full scale, the display will return to the normal operating mode.

NOTE 1: If there is not a minimal response to the cal gas in the first minute, the sensor will enter into the calibration fault mode which will cause the display to alternate between the sensor’s current status reading and the calibration fault screen which appears as: “**SPAN FAULT #1**” (see section 9.3)

NOTE 2: If during the auto-span function the sensor fails to meet a minimum signal stability criteria, the sensor will enter the calibration fault mode which will cause the display to alternate between the sensor’s current status reading and the calibration fault screen which appears as: “**SPAN FAULT #2**” (see section 9.3).

9.3 Additional Notes

1. Upon entering the calibration menu, the 4-20 mA signal drops to 2 mA and is held at this level until you return to normal operation.
2. If during calibration the sensor circuitry is unable to attain the proper adjustment for zero or span, the sensor will enter into the calibration fault mode which will activate the fault LED (see section 11.0) and will cause the display to alternate between the sensor’s current status reading and the calibration fault description. In these cases, the previous calibration points will remain in memory. If this occurs you may attempt to recalibrate by entering the calibration menu as described in section 9.1-a. If the sensor fails again, defer to technical trouble shooting (see section 13.0).

9.4 Calibration Frequency

In most applications, monthly to quarterly calibration intervals will assure reliable detection. However, industrial environments differ. Upon initial installation and commissioning, close frequency tests should be performed, weekly to monthly. Test results should be recorded and reviewed to determine a suitable calibration interval.

10.0 Status of Programming, Calibration Level and Sensor Life

The programming menu has a “View Program Status” listing that allows the operator to view the gas, range, and software version number of the program, as well as the calibration gas level setting, and estimated remaining sensor life. The programming menu also allows the changing of the calibration gas level setting (see section 9.2).

The following procedure is used to view the programming status of the sensor:

- 1) First, enter the programming menu by holding the programming magnet stationary over “PGM 2” for 30 seconds until the display reads “**VIEW PROG STATUS**”, then withdraw the magnet. At this point you can scroll through the programming menu by momentarily waving the programming magnet over “PGM 1” or “PGM 2”. The menu options are: View Program Status, and Set Cal Level.
- 2) Next, scroll to the “**VIEW PROG STATUS**” listing and then hold the programming magnet over “PGM 1” for 3 seconds. The menu will then automatically scroll, at five second intervals, through the following information before returning back to the “**VIEW PROG STATUS**” listing.
 - a) The software version number.
 - b) Range is ###.
 - c) Calibration gas level setting. The menu item appears as: “**CalLevel @ xxPPM**”
 - d) The estimated remaining sensor life. The menu item appears as: “**SENSOR LIFE 100%**”
- 3) Exit back to normal operations by holding the programming magnet over “PGM 2” for 3 seconds, or automatically return to normal operation in 30 seconds.

11.0 Program Features

Detcon MicroSafe™ toxic gas sensors incorporate a comprehensive program to accommodate easy operator interface and fail-safe operation. Program features are detailed in this section. Each sensor is factory tested, programmed, and calibrated prior to shipment.

Over Range

When the sensor detects gas greater than 100% of range, it will cause the display to flash the highest reading of its range on and off.

Under Range Fault(s)

If the sensor should drift below a zero baseline of -10% of range, the display will indicate a fault: “**ZERO FAULT**”. This is typically fixed by performing another zero cal. When the total negative zero drift exceeds the acceptable threshold the display will indicate “**SENSOR FAULT**” and you will longer be able to zero calibrate.

Span Fault #1

If during span calibration the sensor circuitry is unable to attain a minimum defined response to span gas, the sensor will enter into the calibration fault mode and cause the display to alternate between the sensor’s current status reading and the calibration fault screen which appears as: “**SPAN FAULT #1**”. The previous calibration settings will remain saved in memory. Previous span calibration is retained.

Span Fault #2

If during the span routine, the sensor circuitry is unable to attain a minimum defined stabilization point, the sensor will enter into the calibration fault mode and cause the display to alternate between the sensor’s current status reading and the calibration fault screen which appears as “**SPAN FAULT #2**”. Previous span calibration is retained.

Memory Fault

If new data points cannot successfully be stored to memory the display will indicate: “**MEMORY FAULT**”.

Fail-Safe/Fault Supervision

Detcon MicroSafe™ sensors are programmed for fail-safe operation. All fault conditions will illuminate the fault LED, and cause the display to read its corresponding fault condition: “**ZERO FAULT**”, “**SENSOR**

FAULT", "**SPAN FAULT #1**", or "**SPAN FAULT #2**". A "**SENSOR FAULT**" and "**ZERO FAULT**" will cause the mA output to drop to zero (0) mA.

Sensor Life

The "Sensor Life" feature gauges the remaining sensor life based on signal output from the sensor cell. When sensor life of 25% or less remains the sensor cell should be replaced within a reasonable maintenance schedule.

12.0 Universal Transmitter Feature (Re-Initialization)

The Model DM500IS uses a universal transmitter design that allows the transmitter to be set up for any target gas and any toxic concentration range. The original transmitter set-up is done at Detcon Inc. as part of the sensor test and calibration procedure, but it may also be changed in the field if necessary. The Universal Transmitter feature is a significant convenience to the user because it allows hardware flexibility and minimizes the spare parts requirements to handle unexpected transmitter failures of different gas/ranges. It is however, absolutely critical that changes to gas/range set-up of the Universal Transmitter be consistent with the gas type and range of the Intrinsically Safe Sensor Head that it is connected to.

NOTE: If the Universal Transmitter is changed for gas type and range, it must be consistent with the Intrinsically Safe sensor head it is mated with.

If the Universal Transmitter needs to be changed for gas type and range follow this procedure. First, unplug the transmitter temporarily and then plug it back in. While the message "Universal Transmitter" appears, take the program magnet and swipe it over magnet PGM1. This will reveal the set-up options for gas range and gas type.

Swipe over PGM1 to advance through the options for gas range which include:

1, 2, 3...10 ppm

10, 15, 20...100 ppm

100, 200, 300...1000 ppm

1000, 2000, 3000 ...10,000 ppm

When the correct range is displayed, hold magnet over PGM1 for 3 seconds to accept the selection.

Next is your selection for the gas type. In this set-up you will enter the alpha-numeric characters of the gas type. See Table 1 for correct symbols. There is space for the chemical formula up to six characters. Use PGM1 and PGM2 swipes to advance through the alphabet and numbers 0-9 selection (there is a blank space after 9). When the correct alphanumeric character is highlighted, hold the magnet over PGM1 for 3 seconds to lock it in. This moves you to the next blank and the procedure is repeated until the chemical formula is completed. After the 6th character is locked in the transmitter will proceed to normal operation.

NOTE 1: If the gas symbol has more than 6 characters, the symbol can be replaced by an abbreviated version of the target gas name such as TOL or TOLUEN for Toluene which has the symbol C₆H₅CH₃. For Epichlorohydrin (symbol C₃H₅OCL) you can substitute the name EPI or EPICHL etc.

NOTE 2: When the Universal Transmitter is re-initialized and a new gas and range is entered, the previous customer settings span gas value is reset to default levels. This must be re-programmed back to the customer specific settings.

13.0 Trouble Shooting

Sensor reads Over-range after Power-up

Probable Cause: Biased sensor requiring additional stabilization time.

1. Verify if this is a biased sensor (see section 6.0).
2. Wait up to 8 hours for unit to come on-scale if using a low range biased sensor.
3. Verify that there are not large amounts of target gas or interfering gases in background.

Reading Higher than Anticipated

Probable Causes: Target or Interfering gases in background, Incorrect calibration for Zero or Span, Biased sensor still stabilizing.

1. Verify no target or interfering gases are present.
2. Redo Zero and Span calibrations with validated Zero Gas and Span Gas standards.
3. If recovering after a start-up, give more time to stabilize.

Reading Lower than Anticipated

Probable Causes: Target gas or Interfering gases in background during Zero Calibration, Zero Calibration done before unit finished stabilizing, or Incorrect Span Calibration.

1. Redo Zero and Span calibrations with validated Zero Gas and Span Gas standards.

Sensor Fault

Probable Causes: Yellow wire is connected. Sensor has drifted since last zero cal.

1. Perform Zero calibration
2. Re-calibrate sensor

Zero Calibration Fault

Probable Causes: Target gas or Interfering gases in background during Zero Calibration, Failed electrochemical sensor.

1. Verify no target or interfering gases are present.
2. Redo Zero and Span calibrations with validated Zero Gas and Span Gas standards.
3. If recovering after a start-up, give more time to stabilize.

Span Calibration Fault

Probable Causes: Failed electrochemical sensor, ice/mud/dust blocking sensor membrane, invalid span calibration gas do to age and contamination or insufficient flow rate.

1. Verify there is no ice/mud/dust blocking sensor membrane.
2. Redo Span Calibration with validated Span Gas standard (check with Pull Tube).
3. Reinitialize unit by plugging in transmitter while holding the magnet on PGM1. Scroll through and select the correct gas type. Make sure all customer settings are re-entered after “re-initialization”.
4. Replace with new electrochemical sensor.

Noisy Sensor (continuous drift) or suddenly Spiking

Probable Cause: Unstable power source, inadequate grounding, Inadequate RFI protection.

1. Verify power Source output and stability.
2. Contact Detcon for assistance in optimizing shielding and grounding.
3. Add RFI Protection accessory available from Detcon.

Reporting “ERROR @ XXXXXXXX”

Probable Cause: Span calibration calculation error.

1. Reinitialize unit by plugging in transmitter and the swiping the magnet over PGM1 while “Universal Transmitter” is displayed. Scroll through and select the correct gas type and range (see section 12.0). Make sure all customer specific settings are re-entered after “re-initialization”.

14.0 Spare Parts List

943-000006-132	Calibration Adapter
500-005065-007	Connector board
327-000000-000	Programming Magnet
897-850901-010	Aluminum Condulet
897-850901-316	Stainless Steel Condulet
960-202200-000	Condensation prevention packet (replace annually).
925-9954S0-000	DM-5xx Series Universal Plug-in Control Circuit w/OLED
925-8454S0-04P*	DM-5xx-H2 LEL range Series Universal Plug-in Control Circuit w/OLED

* The H2 LEL range transmitter is not universal but is discrete to Hydrogen in the 0-4% by volume range.

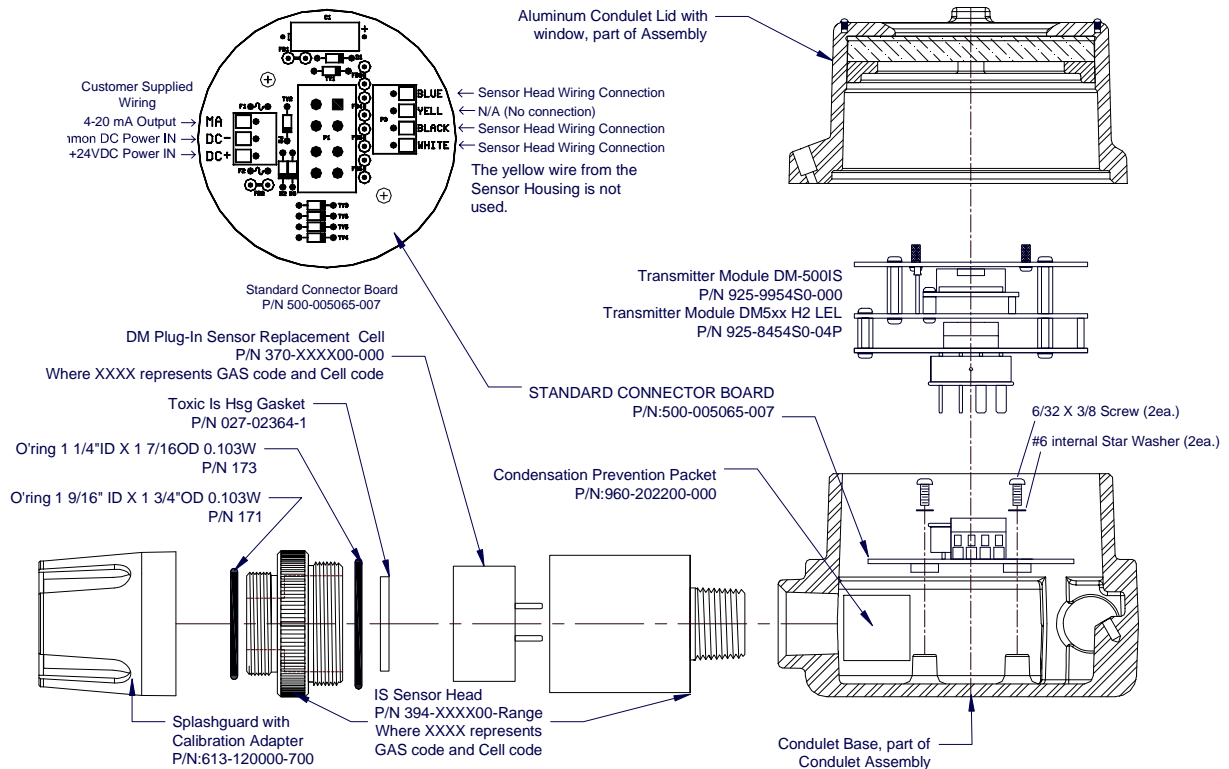

Figure 14 Spare parts diagram

Table 5 IS Sensor Head / Plug-in Replacement Sensor Cell

Model Number	GasName	IS Sensor Head	Plug-in Replacement Sensor Cell
DM-500IS-C2H3O	Acetaldehyde	394-12EA00-Range	370-12EA00-000
DM-500IS-C2H2	Acetylene	394-12EG00-Range	370-12EG00-000
DM-500IS-C3H3N	Acrylonitrile	394-12EM00-Range	370-12EM00-000
DM-500IS-NH3 (-20°C)	Ammonia	394-171700-Range	370-171700-000
DM-501IS-NH3 (-40°C)	Ammonia	394-151500-Range	370-151500-000
DM-502IS-NH3 (CE)	Ammonia	394-505000-Range	370-505000-000
DM-500IS-AsH3	Arsine	394-191900-Range	370-191900-000
DM-500IS-Br2	Bromine	394-747500-Range	370-747500-000
DM-500IS-C4H6	Butadiene	394-12EB00-Range	370-12EB00-000
DM-500IS-CS2	Carbon Disulfide	394-12EH00-Range	370-12EH00-000
DM-500IS-CO	Carbon Monoxide	394-444400-Range	370-444400-000
DM-500IS-COS	Carbonyl Sulfide	394-12EN00-Range	370-12EN00-000
DM-500IS-CL2	Chlorine	394-747400-Range	370-747400-000
DM-500IS-CLO2 (>10ppm)	Chlorine Dioxide	394-747600-Range	370-747600-000
DM-501IS-CLO2 (≤10ppm)	Chlorine Dioxide	394-777700-Range	370-777700-000
DM-500IS-B2H6	Diborane	394-192100-Range	370-192100-000
DM-500IS-C2H6S	Dimethyl Sulfide	394-12EC00-Range	370-12EC00-000
DM-500IS-C3H5OCL	Epichlorohydrin	394-12EI00-Range	370-12EI00-000
DM-500IS-C2H5OH	Ethanol	394-12EO00-Range	370-12EO00-000
DM-500IS-C2H5SH	Ethyl Mercaptan	394-24EZ00-Range	370-24EZ00-000
DM-500IS-C2H4	Ethylene	394-12ED00-Range	370-12ED00-000
DM-500IS-C2H4O	Ethylene Oxide	394-12EJ00-Range	370-12EJ00-000
DM-500IS-F2	Fluorine	394-272700-Range	370-272700-000
DM-500IS-CH2O	Formaldehyde	394-12EP00-Range	370-12EP00-000
DM-500IS-GeH4	Germane	394-232500-Range	370-232500-000
DM-500IS-N2H4	Hydrazine	394-262600-Range	370-262600-000
DM-500IS-H2 (ppm)	Hydrogen	394-848400-Range	370-848400-000
DM-501IS-H2 (LEL)	Hydrogen	394-050500-Range	370-050500-000
DM-500IS-HBr	Hydrogen Bromide	394-090800-Range	370-090800-000
DM-500IS-HCL	Hydrogen Chloride	394-090900-Range	370-090900-000
DM-500IS-HCN	Hydrogen Cyanide	394-131300-Range	370-131300-000
DM-500IS-HF	Hydrogen Fluoride	394-333300-Range	370-333300-000
DM-500IS-H2S	Hydrogen Sulfide	394-242400-Range	370-242400-000
DM-500IS-CH3OH	Methanol	394-12EE00-Range	370-12EE00-000
DM-500IS-CH3SH	Methyl Mercaptan	394-24EK00-Range	370-24EK00-000
DM-500IS-NO	Nitric Oxide	394-949400-Range	370-949400-000
DM-500IS-NO2	Nitrogen Dioxide	394-646400-Range	370-646400-000
DM-500IS-O3	Ozone	394-393900-Range	370-393900-000
DM-500IS-COCL2	Phosgene	394-414100-Range	370-414100-000
DM-500IS-PH3	Phosphine	394-192000-Range	370-192000-000
DM-500IS-SiH4	Silane	394-232300-Range	370-232300-000
DM-500IS-SO2	Sulfur Dioxide	394-555500-Range	370-555500-000
DM-500IS-C4H8S	Tetrahydrothiophene	394-434300-Range	370-434300-000
DM-500IS-C4H4S	Thiophane	394-12EQ00-Range	370-12EQ00-000
DM-500IS-C6H5CH3	Toluene	394-12ER00-Range	370-12ER00-000
DM-500IS-C4H6O2	Vinyl Acetate	394-12EF00-Range	370-12EF00-000
DM-500IS-C2H3CL	Vinyl Chloride	394-12EL00-Range	370-12EL00-000

15.0 Warranty

Detcon, Inc., as manufacturer, warrants each new electrochemical toxic gas plug-in sensor cell, for a specified period under the conditions described as follows: The warranty period begins on the date of shipment to the original purchaser and ends after the specified period as listed in the table in Section 4.0. The sensor cell is warranted to be free from defects in material and workmanship. Should any sensor cell fail to perform in accordance with published specifications within the warranty period, return the defective part to Detcon, Inc., 4055 Technology Forest Blvd. Suite 100, The Woodlands, Texas 77381, for necessary repairs or replacement.

16.0 Service Policy

Detcon, Inc., as manufacturer, warrants under intended normal use each new DM-500IS series plug-in signal transmitter Control Circuit and intrinsically safe Sensor Head circuit to be free from defects in material and workmanship for a period of two years from the date of shipment to the original purchaser. All warranties and service policies are FOB the Detcon facility located in The Woodlands, Texas.

17.0 Revision History

Revision	Date	Changes made	Approval
0	09/11/06	Initial Release	LU
0.1	08/17/15	Update wiring of Sensor and Remote Sensor, update Spare Parts	LU

Shipping Address 4055 Technology Forest Blvd. Suite 100,, The Woodlands Texas 77381
Mailing Address: P.O. Box 8067, The Woodlands Texas 77387-8067
Phone: 888.367.4286, 281.367.4100 • Fax: 281.292.2860 • www.detcon.com • sales@detcon.com