

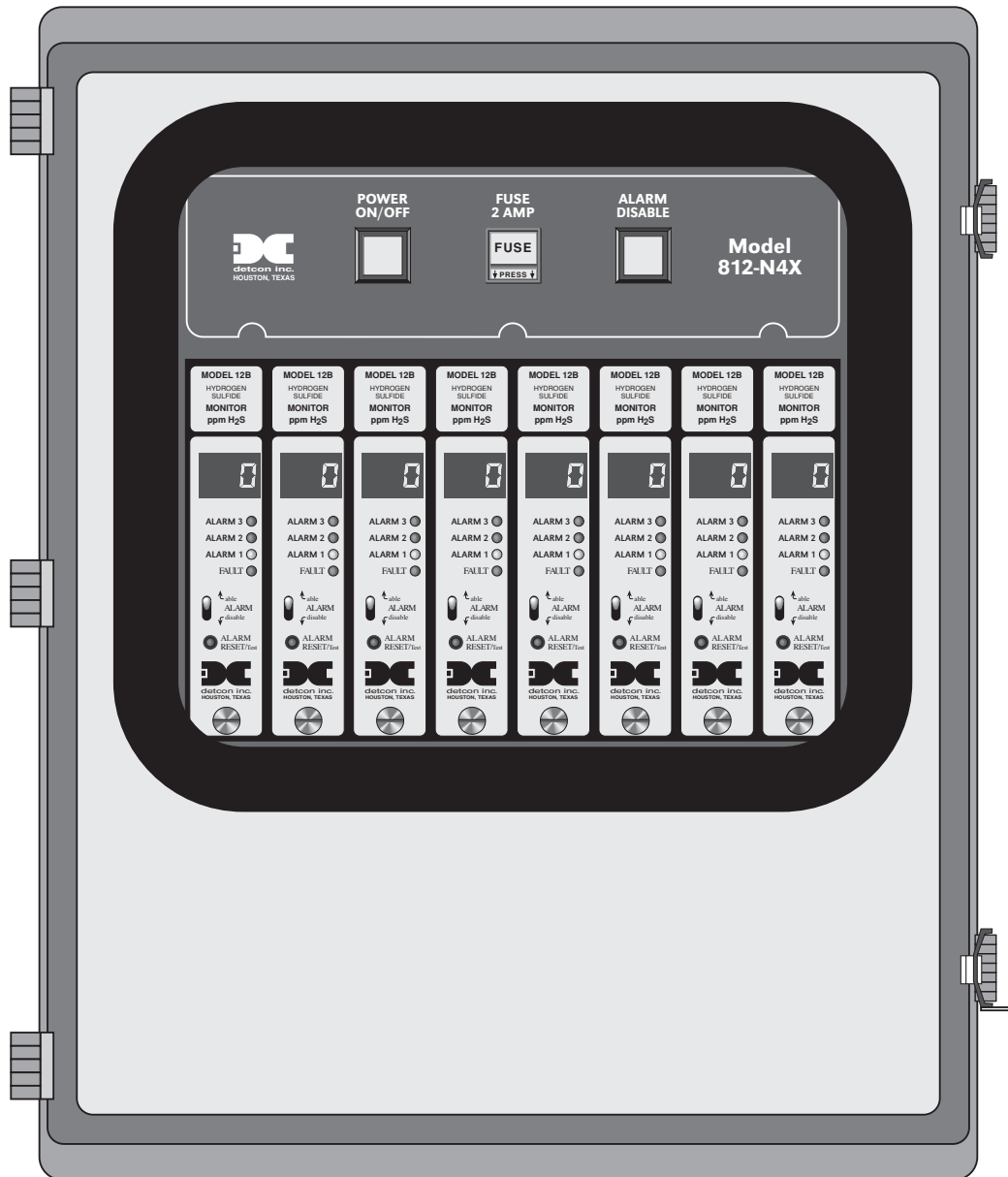

Detcon Model 812-N4X NEMA 4 Control Enclosure



Operator's Installation & Instruction Manual

December 6, 2011 Document #2130 Rev. 1.1

Table of Contents

- 1.0 Introduction
- 1.1 Description
- 1.2 Specifications
- 1.3 Multiple Alarm Relay Circuit
- 1.4 Alarm Disable
- 1.5 Remote Alarm Reset
- 1.6 Installation
- 1.7 Start-up
- 1.8 Maintenance & Repair
- 1.9 Spare Parts List
- 1.10 Warranty

1.0 INTRODUCTION

Detcon Model 812-N4X consists of 3 major assemblies:

1. The NEMA 4 fiberglass control enclosure.
2. The Model 12B single channel digital control modules.
3. The remote mount gas sensor assemblies.

The NEMA 4 control enclosure is detailed in section 1.0 of the manual, the control modules in section 2.0, and applicable sensor assemblies in section 3.0.

1.1 DESCRIPTION

Detcon Model 812-N4X control enclosure, along with Model 12B digital control modules, is designed to serve as a host assembly for up to eight remote mount gas detection sensor assemblies. The control enclosure is rated NEMA 4X, which is by definition rain tight, and therefore suitable for outdoor location in electrically non-hazardous environments.

The single channel modular design supports application flexibility wherein multiple function gas detection systems can be configured in any combination up to eight channels. All control modules are plug-in front panel accessible for easy maintenance and repair. The system is powered by VAC line power and/or 24VDC unless otherwise specified at time of order.

The control enclosure includes, as standard operating controls; a power on/off switch, an alarm disable switch and a line power fuse. Discrete output terminal strips located on the controller motherboard are provided for sensor terminations, Form C dry contact alarm outputs for three alarms plus fault (common and choice of normally open or normally closed), 4-20 mA outputs for remote recording devices, and RS-485 serial Modbus™ output. Terminations are provided for VAC power in, VDC power in, and remote alarm reset. A multiple alarm relay circuit card is also provided along with its respective logic and power terminations.

The Form C relay outputs, may be discrete, zoned, or common by gold plated jumper tabs located on the controller mother board.

1.2 SPECIFICATIONS

Electrical Classification

NEMA 4X

Dimensions

15.75"W x 18"H x 9.75"D

Capacity

8 single channels

Power Input

85-264VAC/24VDC

Power Consumption

5 watts per channel (full alarm peak load)

Outputs

Discrete Analog 4-20 mA DC

Serial RS-485 Modbus™

Discrete or zoned alarm relays

Contacts include common with jumper selectable choice (on controller) of normally-open or normally-closed for four alarms

Resistive load: 5A, 250 VAC; 5A, 30 VDC

Inductive load: 2A, 250 VAC; 2A, 30 VDC

Max. operating current: 5A

Operating Temperature Range

-40°F to +175°F

Warranty

One year

1.3 MULTIPLE ALARM RELAY CIRCUIT

A multiple alarm relay circuit (referred to in further text as MARC) mounted on the controller mother board is provided with each Detcon Model 812-N4X. The MARC (figure 1) consists of 4 interposing relays (contacts are rated 10 amp @ 120 VAC/8 amp @ 30 VDC) with 24VDC coils as standard. Other coil voltage ratings must be specified at time of order. The MARC can be configured to output Form C dry contacts (common, normally open and normally closed), AC power or DC power. A 5 amp microfuse is provided for each relay and is configured in series with the common pole of its respective relay. This configuration is functional regardless of whether Form C dry contacts, AC power or DC power outputs are used.

An in/out termination is provided for applying AC or DC power into any one of the interposing relays. A gold plated jumper tab is used to apply the in/out power option to its corresponding relay, thus the 4 relays may be used in a combination of Form C dry contacts and DC outputs or Form C contacts and AC outputs.

The terminations labeled "Alarm Coil Power" located on the left of the 812-N4X motherboard are used only for coil power. The "+" termination may be used to provide for various relay logic through the Form C dry contacts terminals of each individual Model 12B channel located on the 812-N4X motherboard. The "-" termination should be wired into the common terminal (shown by a common symbol) located on the left of the MARC.

The terminations labeled "Alarm Power" located on the left of the 812-N4X motherboard are used for providing power to the In/Out termination on the MARC. As can be seen in the 812-N4X schematic/wiring diagram (figure 2), the alarm power terminations for AC come directly from the AC input terminals located above on the 812-N4X motherboard. The same is true of the DC power terminations.

Note: DC power used to drive alarms must be obtained through a remote DC power source. The remote DC power source should be terminated to the terminals labeled "DC IN" located on the 812-N4X motherboard. The "DC IN" terminations function as both an alternative DC source used to power the 812-N4X as well as provide power for DC alarms. The 812-N4X power supply is not capable of providing power for alarm devices.

Mounting hardware is pre-installed on the 812-N4X motherboard for an additional multiple alarm relay circuit. See section 1.9 for part number and ordering information.

Figure 1

Multiple Alarm Relay Circuit

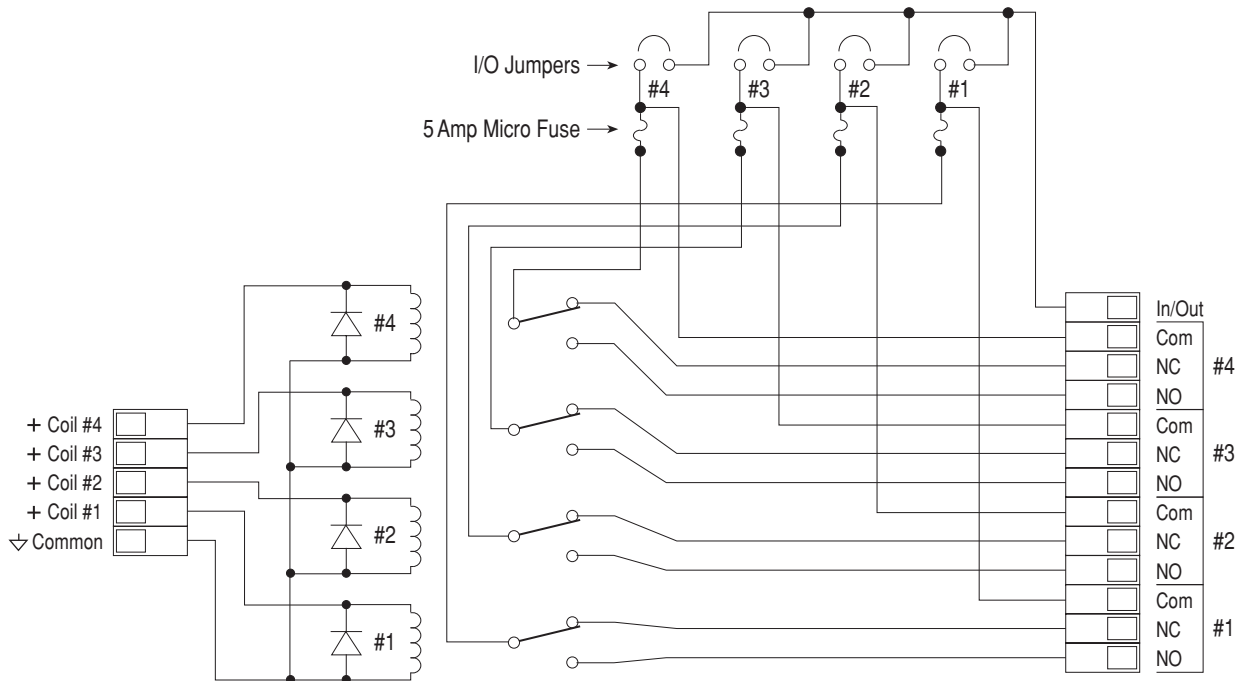
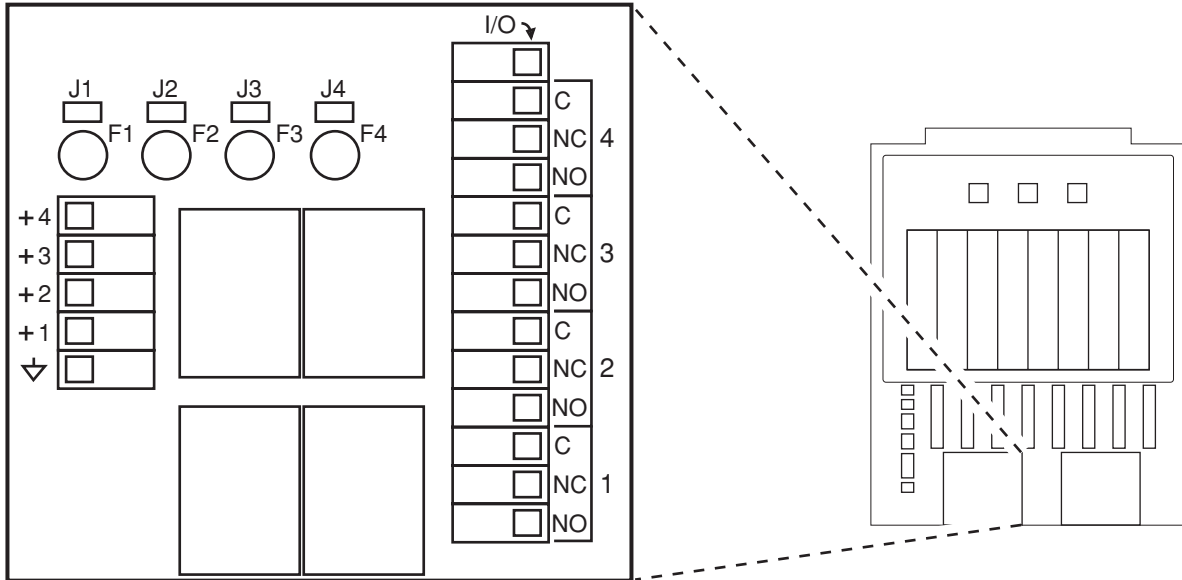
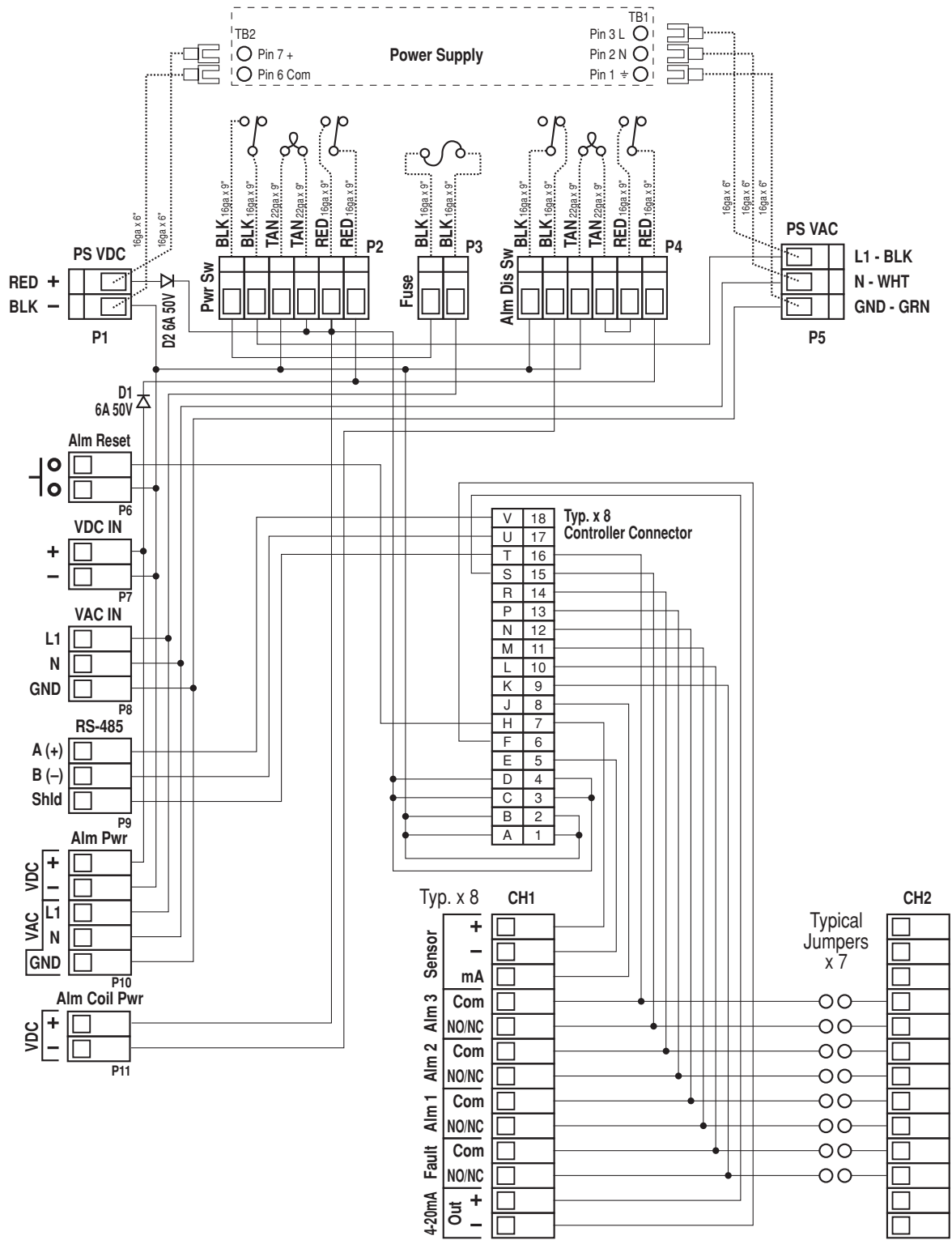

Figure 2



1.4 ALARM DISABLE

The alarm disable switch, located on the front panel (figure 3), operates by removing DC common from the “Alarm Coil Power” terminals. Disabling of alarms does not inhibit any function of the Model 12B digital control modules. The digital display, alarm LEDs and on board alarm relays remain active.

Figure 3

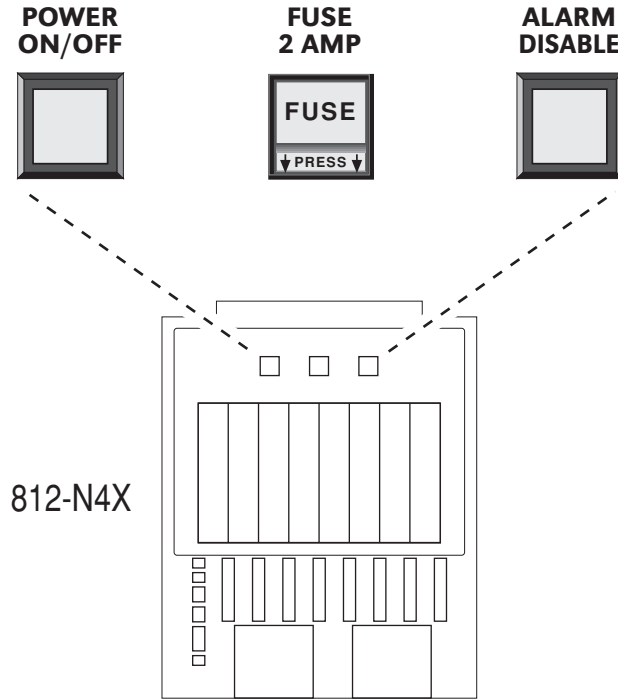

1.5 REMOTE ALARM RESET

A remote mounted normally open momentary switch may be used to reset the alarms of all Model 12B controllers (figure 4). The reset function is effective when the Model 12B’s respective alarms have been programmed in the latching position and alarm conditions have passed. Each Model 12B controller has its own alarm reset switch which is discussed further in section 2.0.

Figure 4

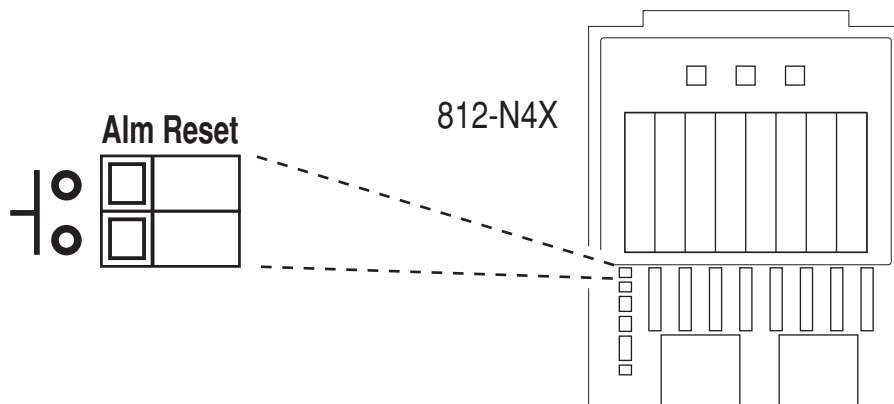

1.6 INSTALLATION

1. Securely mount the 812-N4X enclosure in accordance with the drawing in figure 5.

Figure 5

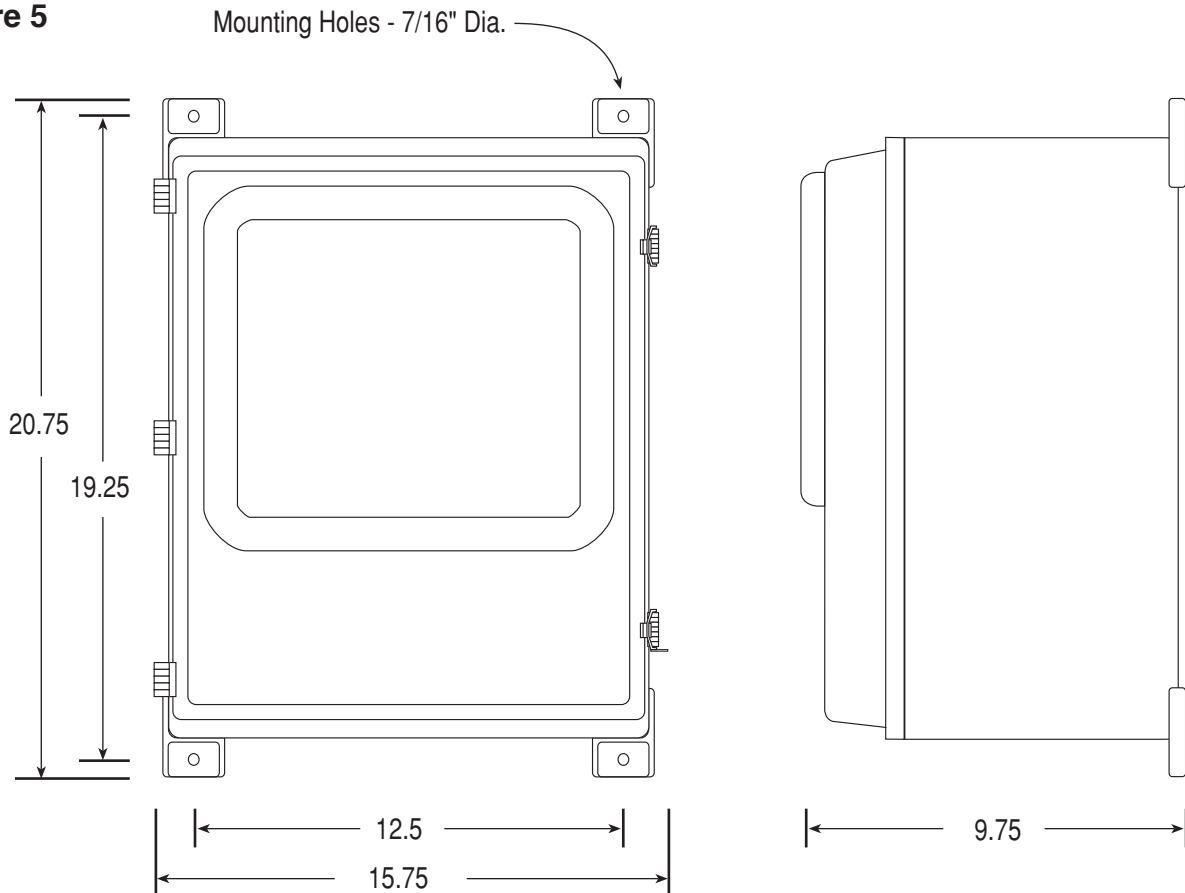

Note: Reference figure 6 for wiring terminations.

Caution: Observe correct polarity when terminating all input/output field wiring. Failure to do so may result in circuit damage on power up.

2. Connect 85-264 VAC input to the terminal strip labeled “VAC IN” (L1, N, GND).
3. If applicable, connect a 24VDC source or standby battery to the terminal strip labeled “VDC IN” (+ and -).
4. Refer to installation and wiring detail of remote mount sensor assemblies as detailed in section 3.0. Terminate field wiring from sensors to the 812-N4X motherboard. Terminals are labeled “Sensor” (mA, + and -).
5. If applicable, terminate the discrete 4-20 mA outputs to external device(s). Terminals are labeled “4-20mA Out” (+ and -).
6. If applicable, terminate the RS-485 serial output to external device(s). Terminals are labeled “RS-485” (A+, B-, and Shield).
7. Based on the application and use of relay contact outputs, complete all wiring terminations prior to application of power. Shut-in controls may be omitted until system test is complete. Terminals are labeled “ALARM 1” (Com & NO/NC), “ALARM 2” (Com & NO/NC), “ALARM 3” (Com & NO/NC), and “Fault” (Com & NO/NC). Relay contact outputs may be discrete or zoned via the gold-plated jumper tabs. Relay contact outputs may be used in conjunction with the multiple alarm relay circuit as described in section 1.3.

8. If applicable, connect a normally open momentary remote mounted switch to the terminal strip labeled “Alarm Reset”.

Figure 6

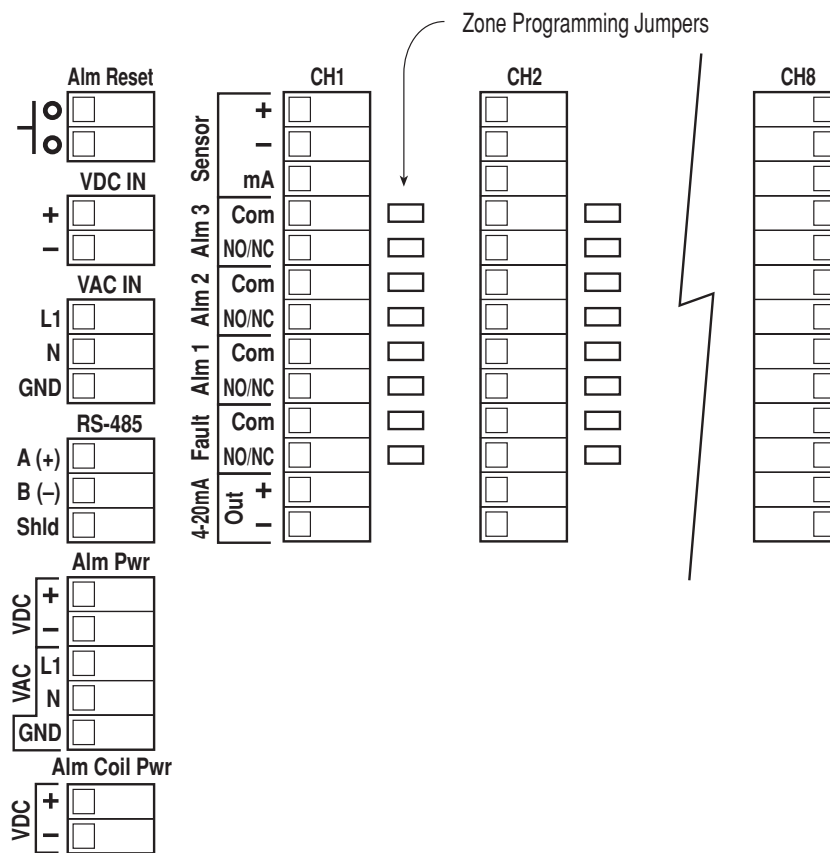

1.7 START UP

Upon completion of all field wiring: Depress the power switch located on the front panel. Note that each Model 12B controller digital display illuminates. Varying readings may occur during sensor warm-up. A 10 second alarm delay will occur on power up. Refer to section 3.0 for additional sensor start-up detail.

1.8 MAINTENANCE & REPAIR

The Detcon Model 812-N4X’s modular design allows for minimum down time during maintenance and/or repair. The model 12B control modules may be changed by simply loosening its mounting screw and sliding the module out of its card cage. See section 3.0 for more information on the 12B control module.

Replacement of the power switch, fuse holder, or alarm disable switch is accomplished by: removing the 10 screws that secure the 812-N4X face plate; disconnecting the three plugs from their respective headers; remove the wires from the plug of the component to be replaced; snap the component out of the 812-N4X face plate and then reassembly with the new component. Reference figure 2 for wiring details.

Replacement of the power supply is accomplished by: removing the 10 screws that secure the 1212F-FB face plate; disconnecting the three plugs from their respective headers; disconnect the two power supply plugs from their respective headers; remove the three screws that hold the power supply bracket the PCB motherboard; remove the four screws that hold the power supply bracket to the power supply; disconnect the wires from the power supply and then reassembly with the new power supply. Reference figure 2 for wiring details.

1.9 SPARE PARTS LIST

<u>Part #</u>	<u>Description</u>
5026	Multiple alarm relay circuit
0295	5 amp micro fuse
3618-MAP-24	130 watt, 24 VDC switcher power supply
0224	Gold plated jumper tab
2812	24 VDC lamp for power and alarm disable switch
0298	2 amp 3AG slow blow fuse
320-3217-1	Power switch assembly
320-3217-2	Alarm Disable switch assembly
2806	Green switch cap (for power switch)
2807	Red switch cap (for alarm disable switch)
3280	Fuse holder

1.10 WARRANTY

Detcon Inc., as manufacturer, warrants under intended normal use each new Model 812-N4X NEMA 4X control enclosure to be free from defects in material and workmanship for a period of one year. The warranty period begins from the date of shipment to the original purchaser and ends one year thereafter. All warranties and service policies are FOB the Detcon Inc. facility located in The Woodlands, Texas.

Mailing Address: P.O. Box 8067, The Woodlands, Texas 77387-8067
phone 888-367-4286, 281-367-4100 • fax 281-292-2860 • www.detcon.com • sales@detcon.com