



Model 1010-N4X Model 1010-N4X-SS NEMA 4X Control Enclosures



Operator's Installation and Instruction Manual

Covers 1010-N4X and 1010-N4X-BBU
In epoxy molded and stainless steel enclosures

◆ DETCON, Inc.
3200 Research Forest Dr.,
The Woodlands, Texas 77387
Ph.281.367.4100 / Fax 281.298.2868
www.detcon.com

Page intentionally blank

Table of Contents

1.0 Introduction.....	1
1.1 Description	1
1.2 Specifications	1
1.3 Auxiliary Alarm Relay Board (AARB).....	2
1.4 Remote Alarm Reset	3
2.0 Installation.....	4
2.1 Alarm and Fault Jumpers	6
2.2 Start Up	6
3.0 Maintenance & Repair	7
4.0 Spare Parts List.....	9
5.0 Warranty	9
Appendix C	10
Revision History.....	10

Table of Figures

Figure 1 Auxiliary Alarm Relay Board.....	2
Figure 2 Mounting the 1010-N4X Enclosure.....	4
Figure 3 Mounting the 1010-N4X stainless Steel Enclosure	4
Figure 4 Motherboard Wiring Diagram	5
Figure 5 Backplane Configuration Jumpers.....	6
Figure 6 Power Supply Wiring.....	7

Page intentionally blank

Shipping Address: 3200 A-1 Research Forest Dr., The Woodlands Texas 77381

Mailing Address: P.O. Box 8067, The Woodlands Texas 77387-8067

Phone: 888.367.4286, 281.367.4100 • Fax: 281.292.2860 • www.detcon.com • sales@detcon.com

1.0 Introduction

Detcon Model 1010-N4X Gas Detection System consists of 3 major assemblies:

1. The 1010-N4X Fiberglass or Stainless Steel control enclosure.
2. The Model 10 single channel digital control modules.
3. The remote mount gas sensor assemblies.

The NEMA 4X control enclosure is detailed in this manual; the Model 10 Control Modules are detailed in the Detcon Model 10 Operators Installation and Instruction Manual, and applicable sensor assemblies in their corresponding Operators Installation and Instruction Manual.

1.1 Description

Detcon Model 1010-N4X and 1010-N4X-SS control enclosure, along with Model 10 Control Modules, is designed to serve as a host assembly for up to ten remote mount 4-20mA gas detection sensors. The control enclosure is rated NEMA 4X, which is by definition rain tight and therefore suitable for outdoor location in electrically non-hazardous environments. All control modules are plug-in front panel accessible for easy maintenance and repair. The unit is powered by 110~240VAC unless otherwise specified at the time of order.

Discrete output terminal strips located on the controller motherboard are provided for sensor terminations. 4-20mA outputs for remote recording devices and an RS-485 serial ModBus™ output are also located on the motherboard. VDC power in, and remote alarm reset terminations are also provided on the Motherboard.

Form-C relay outputs from each Control Module are provided for Alarm 1, Alarm 2, and Fault conditions. These relay outputs can be configured as discrete or zoned as determined by jumpers located between the channels on the motherboard and the relay settings determined by the dipswitches on the Model 10 Control Modules.

1.2 Specifications

Electrical Classification

NEMA 4X

Dimensions

16 "H x 14"W x 9"D

Capacity

10 single channels

Power Input

110~240VAC/24VDC

Power Consumption

<5 watts per channel (includes gas sensor and control modules; Does not include annunciators.)

Outputs

Discrete Analog 4-20mA DC

Serial RS-485 Modbus™

Discrete or zoned alarm relays (Alarm 1, Alarm 2, and Fault located on associated Mod 10 Control Modules. See the appropriate Mod 10 Control Module Manual for more information.)

Operating Temperature Range

-40°C to +75°C

Battery Backup (If applicable)

2ea. 12V 2.9Ah batteries in series; ½ hour minimum operating time

Low Voltage Cut-off Board

Warranty

One year

1.3 Auxiliary Alarm Relay Board (AARB)

An Auxiliary Alarm Relay Board is included with each Detcon Model 1010-N4X. The board is mounted on the bottom quadrant of the motherboard. The AARB (Figure 1) consists of four interposing relays (contacts are rated 10Amp @ 120VAC and 8Amp @ 30VDC) with 24VDC coils. The AARB can be configured for Form-C dry contacts (common, normally open and normally closed), AC power, or DC power.

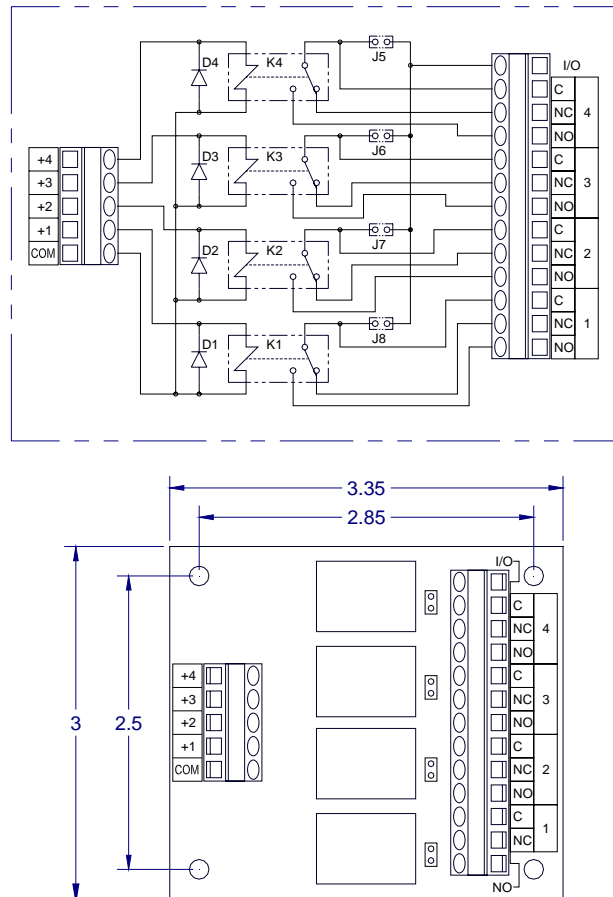

Figure 1 Auxiliary Alarm Relay Board

An ‘IN/OUT’ termination is provided for applying AC or DC power to any one of the interposing relays. A gold plated jumper tab is used to apply the power option to the corresponding relay(s). The 4 relays may be used in any combination of Form-C dry contacts, DC outputs, and AC outputs. The terminations labeled “ALM COIL PWR” (P20) located on the lower left of the motherboard are used to power the relay coils on the AARB. Terminals P1+4, P1+3, P1+2, and P1+1 on the AARB provide for various relay logic setups through the Form-C dry contact terminals of each Model 10 Control Module. P1-COM on the AARB should be wired directly back to P20-2 (ALM COIL PWR (-)) on the motherboard.

The terminations labeled “ALM PWR” located on the left of the 1010-N4X motherboard can be used to provide power to the In/Out termination on the AARB (AARB P2-IN/OUT). Alarm power terminations for AC (P18) come directly from the AC input terminals (P16) on the 1010-N4X motherboard. The DC power terminations at P18 come directly from the VDC IN Terminals (P15).

NOTE: DC power used to drive alarms must be obtained through a remote DC power source. The remote DC power source should be terminated at P15 labeled “VDC IN” located on the 1010-N4X motherboard. Terminal Block P15 (VDC IN) functions as an alternative DC power source used to power

the 1010-N4X and as power for DC alarms. The 1010-N4X power supply is not designed to provide power for alarm devices.

NOTE: If the Battery Option is installed (1010-N4X-BBU), the batteries are connected to P5 (VDC IN). *Do not use* the DC output of “ALM POWER” (P18-1 and P18-2). The Batteries are not designed to provide power for alarm devices.

Mounting hardware is provided on the 1010-N4X motherboard for two additional Auxiliary Alarm Relay Boards.

1.4 Remote Alarm Reset

A remote mounted normally open momentary switch may be used to reset the alarms of all Model 10 controllers. “ALM RESET” (P14-1 and P14-2) provides a set of terminals to connect the switch across every Model 10 Controller (Figure 4). The reset function is effective when the Model 10’s respective alarms have been programmed in the latching position and alarm conditions have passed. Each Model 10 controller also has its own discrete alarm reset switch, discussed further in the Model 10 Controller Manual.

2.0 Installation

1. Securely mount the 1010-N4X Enclosure in accordance with Figure 2 or Figure 3.

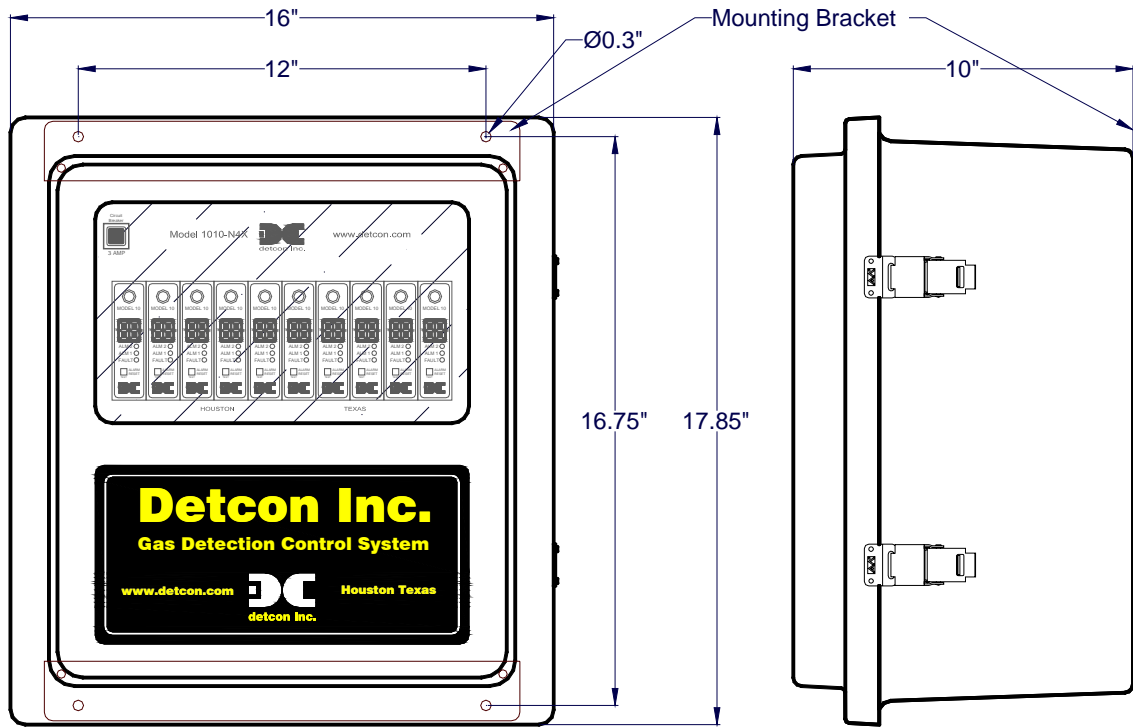

Figure 2 Mounting the 1010-N4X Enclosure

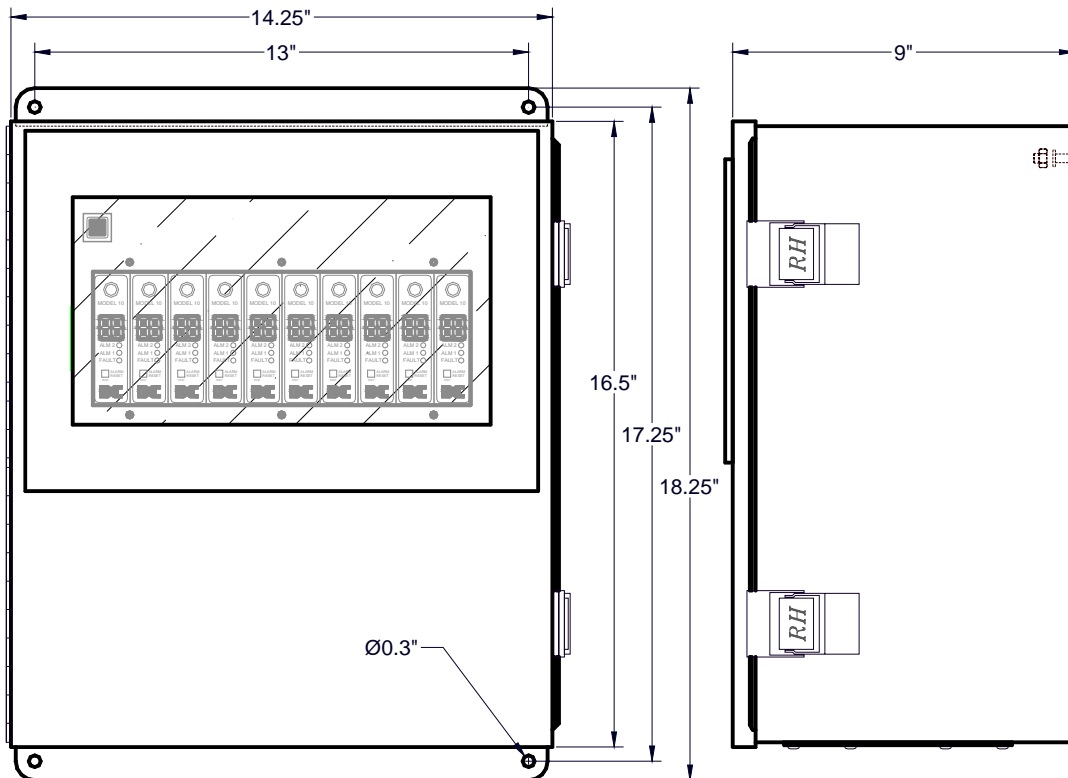

Figure 3 Mounting the 1010-N4X stainless Steel Enclosure

2. Refer to installation and wiring detail of remote mount sensor assemblies as detailed in the Sensor Instruction Manual. Terminate field wiring from sensors on the 1010-N4X motherboard. Terminals are labeled “Sensor” (mA, + and –, Figure 4).
3. If applicable, terminate the discrete 4-20mA outputs to external device(s). Terminals are labeled “4-20 Out” (+ and –, Figure 4).

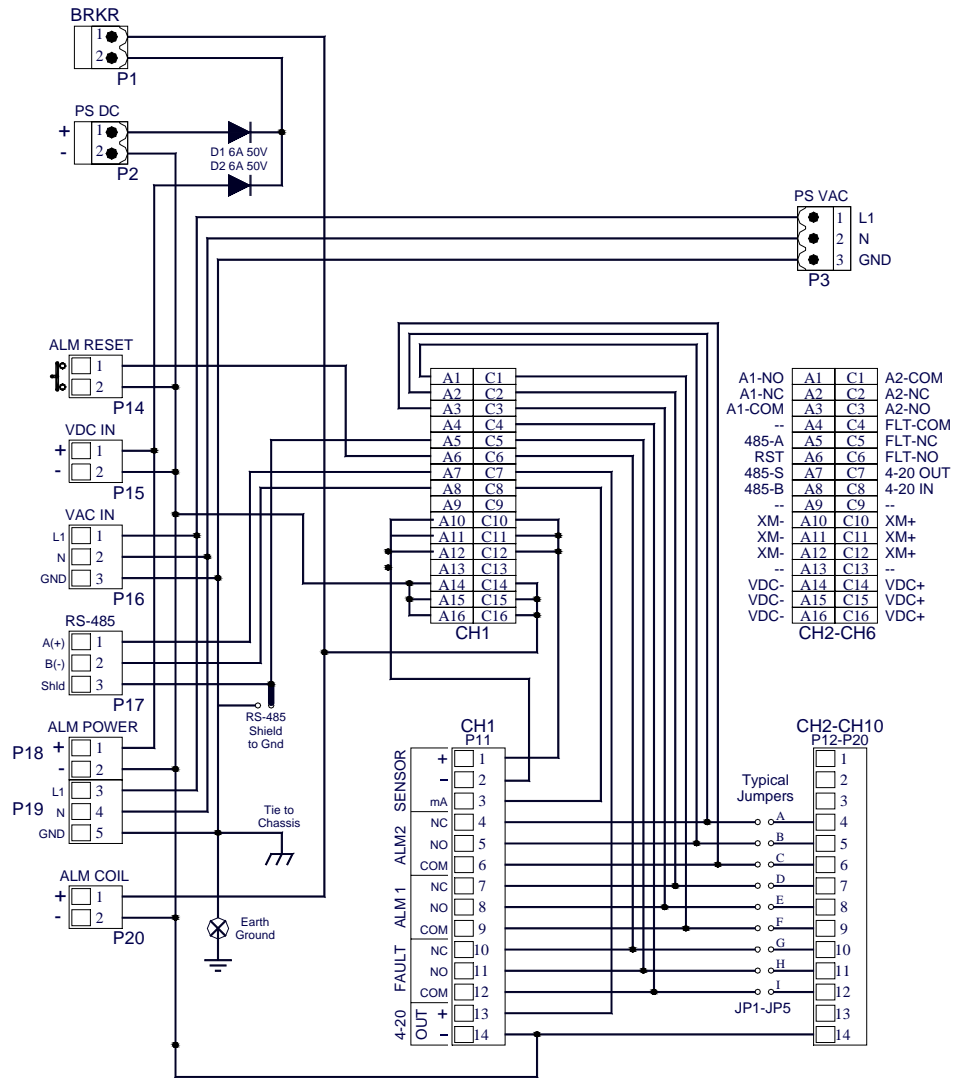

Figure 4 Motherboard Wiring Diagram

4. If applicable, terminate the RS-485 serial output to external device(s). Terminals are labeled “RS-485” (A+, B–, and Shield, Figure 4). If applicable, terminate RS-485 Shield to Earth Ground via the jumper tab located to the left of the RS-485 terminals. Place the jumper on the bottom 2 contacts to tie RS-485 shield to Earth Ground or place the jumper tab on the top two terminals for storage.
5. If applicable a Remote Reset Switch can be utilized by connecting a Momentary, Normally-Open Switch to P4 (ALM RESET).
6. Earth Ground can be connected to the ground point located in the lower left quadrant of the motherboard.

- If applicable, connect a 24VDC source or standby battery to the terminal strip labeled “VDC IN” (P5+ and -) on the Motherboard (Figure 4).

NOTE: If the unit has the Battery Backup Option installed (1010-N4X-BBU), do not connect an external power source to P15.

- Connect 110/220VAC input wiring to the terminals labeled “VAC IN”; P16-1 (L), P16-2 (N), and P16-GND Ground (Figure 4). The Power Supply will accept input voltages from 100 to 240VAC, 50/60Hz.

2.1 Alarm and Fault Jumpers

A bank of jumpers is provided between each channel for use in setting up alarm and fault schemes. These jumpers can be installed or removed to create discrete or zoned alarm/fault schemes in conjuncture with the Model 10 Control Module relay settings. With all of the jumpers installed on the motherboard, the relays on the Control Modules are placed in parallel with each other. (I.E. All of the Alarm 1 relays are in parallel, all of the Alarm 2 relays are in parallel, and all of the Fault Relays are in parallel.) In this configuration, the normally open (“NO”) contacts of the relays would be used to generate an alarm or fault condition, as contact closure on any Control Module would create continuity between the “COM” contact and the “NO” contact output for that alarm or fault. A scheme for alarms should be conceived before power is applied to the unit, and the unit should be set up accordingly. For aid in setting up an appropriate alarm/fault scheme, contact Detcon Customer Service.

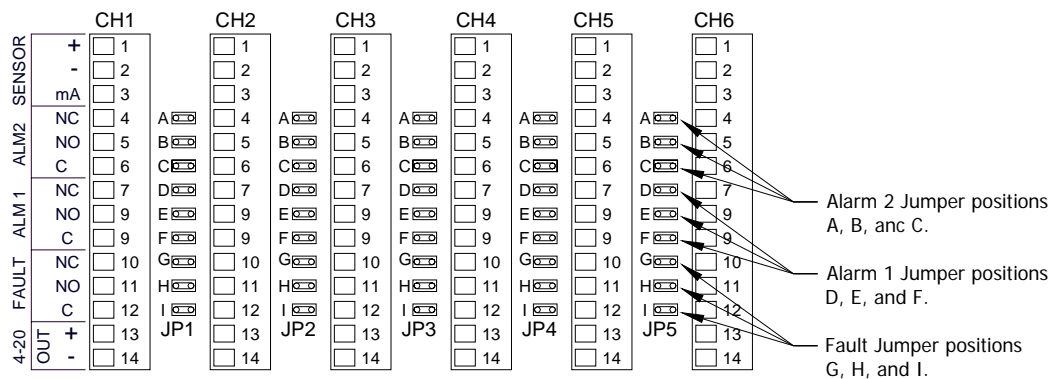

Figure 5 Backplane Configuration Jumpers

2.2 Start Up

Upon completion of all field wiring: Apply power to the 1010-N4X by setting the 3Amp Circuit Breaker (the Circuit Breaker is also a Power Switch, labeled ‘3Amp’) on the front on the Card Cage. Note that each Model 10 controller digital display illuminates.

NOTE: Varying readings may occur during sensor warm-up. A 10 second alarm delay will occur on power up. Refer to the applicable Sensor Instruction Manual for additional sensor start-up details.

3.0 Maintenance & Repair

The Detcon Model 1010-N4X's modular design allows for minimum 'down-time' during maintenance and/or repair.

Model 10 Control Modules

A Model 10 control module may be changed by simply loosening its mounting screw and sliding the module out of its card cage. See the Model 10 Instruction Manual for more information on the Model 10 controllers.

Circuit Breaker/Power Switch

If the 3Amp Circuit Breaker/Power Switch should trip due to a high current or over voltage, the circuit breaker can be reset by pushing the breaker in ('ON'). If the breaker trips again, a problem has occurred that will need to be alleviated before power can be restored.

NOTE: The circuit Breaker/Power Switch does not remove VAC from the Power Supply or the Motherboard. If power is to be completely removed from the unit, the VAC must be disconnected from the source.

NOTE: On units with Battery Backup installed (1010-N4X-BBU), the Circuit Breaker will remove power from the Unit, but does not disconnect the Battery circuit from the Motherboard or the Low Voltage Cutoff Board. The Batteries must be unplugged as well as disconnecting the VAC from the source to remove power completely from the unit.

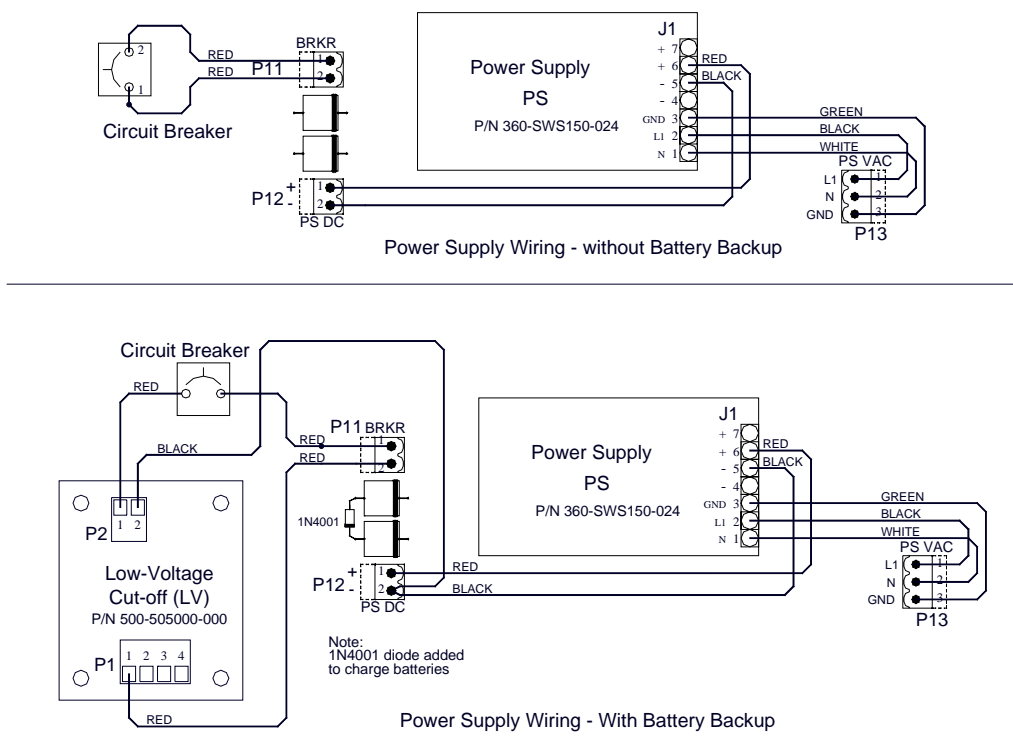

Figure 6 Power Supply Wiring

Power Supply

Replacement of the power supply is accomplished by, removing the 10 screws that secure the 1010-N4X face plate, disconnecting all wiring to/from the power supply, and removing the three screws holding the power supply bracket to the Motherboard. Remove the four screws that hold the power supply bracket to the power supply and reassembly with the new power supply. (Figure 6) Power Supply wiring is different between units with and units without the battery backup option; attention should be paid to the correct wiring scheme for the unit being worked on.

4.0 Spare Parts List

Part #	Description
224	Gold plated jumper tab
320-228861-103	3Amp Circuit Breaker/Power Switch
360-SWS150-024	150 watt, 24 VDC switching power supply
500-502600-000	Auxiliary Alarm Relay Board
500-505000-000	Low Voltage Cut-off PCB (Battery Backup Units only)
344-400000-000	12V 7Ah Battery (Battery Backup Units only)

5.0 Warranty

Detcon Inc., as manufacturer, warrants under intended normal use each new Model 1010-N4X NEMA 4X control enclosure to be free from defects in material and workmanship for a period of one year. The warranty period begins from the date of shipment to the original purchaser and ends one year thereafter. All warranties and service policies are FOB the Detcon Inc. facility located in The Woodlands, Texas.

Appendix C

Revision History

Revision	Date	Changes made	Approval
2.0	05/27/10	Updated to Word, removed irrelevant Common Alarm Section	B. Masi
2.1	07/22/11	Updated drawings to remove reference to common alarm	LU

Shipping Address: 3200 A-1 Research Forest Dr., The Woodlands Texas 77381

Mailing Address: P.O. Box 8067, The Woodlands Texas 77387-8067

Phone: 888.367.4286, 281.367.4100 • Fax: 281.292.2860 • www.detcon.com • sales@detcon.com